

## Preface

---

# Driver and Vehicle Standards Agency

## The MOT Inspection Manual

### Private Passenger and Light Commercial Vehicle Testing

#### Preface

This Manual sets out the testing procedures and standards for those who carry out statutory testing of cars, private buses and light commercial vehicles.

Vehicle owners may also find the Manual useful because it details the inspection to which vehicles are subjected and the reasons why an MOT test certificate could be refused.

This Manual was based on the domestic legislation in force at the time of publication and complies with Annex I to Directive 2014/45/EU.

Future changes in legislation, or in vehicle or equipment design may result in variations to the test requirements.

General information regarding documentation and the responsibilities of those involved in testing are contained in the Driver and Vehicle Standards Agency MOT Testing Guide.

#### Written by the Driver and Vehicle Standards Agency

© Crown copyright. Published by the Driver and Vehicle Standards Agency– to whom applications to reproduce material should be made in writing c/o Corporate Office, Berkeley House, Croydon Street, Bristol, BS5 0DA.

First Edition crown copyright 1992

Fifth consolidated edition 2002

Second Edition crown copyright 2004

Third Edition crown copyright 2010

Fourth Edition crown copyright 2011

Fifth Edition crown copyright 2017

# Contents

---

<b>Introduction</b>	Abbreviation and definitions Introduction Recommended inspection routine
<b>Section 0</b>	<b>Identification of the vehicle</b>
0.1	Registration plates
0.2	Vehicle identification number
<b>Section 1</b>	<b>Brakes</b>
1.1	Condition and operation
1.2	Service brake performance and efficiency
1.3	Secondary brake performance and efficiency
1.4	Parking brake performance and efficiency
1.5	Additional braking device (retarder) performance
1.6	Anti-lock braking system
1.7	Electronic braking system
1.8	Brake fluid
<b>Section 2</b>	<b>Steering</b>
2.1	Mechanical condition
2.2	Steering wheel and column or handlebar, forks and yokes
2.3	Steering play
2.4	Not in use
2.5	Not in use
2.6	Electronic power steering
<b>Section 3</b>	<b>Visibility</b>
3.1	Field of vision
3.2	Condition of glass
3.3	View to rear
3.4	Windscreen wipers
3.5	Windscreen washers
<b>Section 4</b>	<b>Lamps, reflectors and electrical equipment</b>
4.1	Headlamps
4.2	Front and rear position lamps, end outline marker lamps and daytime running lamps
4.3	Stop lamps
4.4	Direction indicators and hazard warning lamps
4.5	Front and rear fog lamps
4.6	Reversing lamps
4.7	Rear registration plate lamps
4.8	Rear reflectors
4.9	Tell-tales mandatory for lighting equipment
4.10	Trailer electrical socket
4.11	Electrical wiring
4.12	Not in use
4.13	Battery(ies)
<b>Section 5</b>	<b>Axles, wheels, tyres and suspension</b>
5.1	Axles
5.2	Wheels and tyres
5.3	Suspension

# Contents

---

<b>Section 6</b>	<b>Body, structure and attachments</b>
6.1	Structure and attachments
6.2	Body and interior
<b>Section 7</b>	<b>Other equipment</b>
7.1	Seat belts and supplementary restraint systems (SRS)
7.2	Not in use
7.3	Anti-theft device
7.4	Not in use
7.5	Not in use
7.6	Not in use
7.7	Audible warning (Horn)
7.8	Speedometer
7.9	Not in use
7.10	Speed limiter
7.11	Not in use
7.12	Electronic stability control (ESC)
<b>Section 8</b>	<b>Nuisance</b>
8.1	Noise
8.2	Exhaust emissions
8.3	Not in use
8.4	Other environmental items
<b>Section 9</b>	<b>Supplementary tests for buses and coaches</b>
9.1	Doors
9.2	Not in use
9.3	Not in use
9.4	Not in use
9.5	Not in use
9.6	Passenger grab handles
9.7	Steps and stairs
<b>Section 10</b>	<b>Seat belt installation checks</b>
10.1	Seat belt installation guidance notes
10.2	Seat belt installation diagrams
<b>Appendix A</b>	<b>Structural integrity and corrosion</b>
<b>Appendix B</b>	<b>Tyre load index tables</b>
<b>Appendix C</b>	<b>Seat belt fitment tables</b>

# Introduction

---

## Introduction - Contents

1. Abbreviations and definitions
2. Application (Classes 3, 4, 5 and 7)
3. Vehicles of historical interest (over 40 years old)
4. Refusal to test
5. Narrow track vehicles
6. Vehicle 'first used' dates - Application of test criteria
7. The Inspection Manual
8. Vehicle Technical Data
9. The MOT Testing Guide
10. Assessment of component condition
11. Definition of insecure
12. Unsafe modification
13. Extensively modified vehicles
14. Inspection procedure
15. Road testing
16. Disabled driver's controls
17. Health and safety
18. Recording defects
19. Retest following failure
20. Recommended inspection routine

# Introduction

## 1. Abbreviations and Definitions

Abandon	The term for when a test cannot be completed because the TESTER considers it unsafe to continue or because it becomes apparent during the test that certain items cannot be satisfactorily inspected. An appropriate fee may be charged for the test.
Abort	The term for when a test cannot be completed because of a problem with the test equipment or the tester. No fee may be charged for the test.
AE	Authorised Examiner - the organisation that operates and manages one or more VTS and is responsible for controlling the quality of testing carried out. Except in the case of a 'sole trader' the AE is not a person but a legal entity, such as a company or partnership.
ATL	Automated Test Lane - These are lanes authorised by DVSA which use wheel play detectors and an automated roller brake tester.
Bodied vehicles	A bodied vehicle is defined as 'a vehicle with a structure consisting/comprising of a floor pan and panels which, with a roof fully encloses the vehicle occupants and without a roof encloses them other than where the roof would be'.  As a guide, if the driver sits in the vehicle with surrounding structure it would be classed as bodied.
Bus	A motor vehicle which is constructed or adapted to carry more than eight seated passengers (see also Minibus).
Category L2e vehicle	A three wheeled vehicle (tricycle) classed as a moped – a maximum speed not exceeding 45km/h, not more than 50cc for spark ignition engine or 4KW for any other power unit.
Category L5e vehicle	A three wheeled vehicle (tricycle) more than 50cc and/or a maximum speed greater than 45km/h.
Category L6e vehicle	Light quadricycle – four wheeled vehicle with a maximum unladen mass of 350kg (not including the batteries in an electrically powered vehicle) a maximum speed not exceeding 45km/h, not more than 50cc for spark ignition engine or 4KW for any other power unit.
Category L7e vehicle	Quadricycle – A four wheeled vehicle with a maximum unladen mass 400kg or 550kg for a goods vehicle (not including the batteries in an electrically powered vehicle) and a maximum net power of 15KW (21BHP).
Category M1 vehicle	A vehicle with four or more wheels used for the carriage of passengers, comprising not more than 8 passenger seats in addition to the driver's seat. This includes dual purpose vehicles, motor caravans and ambulances, but does not include quadricycles.
Category M2 vehicle	A vehicle with four or more wheels used for the carriage of passengers, comprising more than 8 passenger seats in addition to the driver's seat and a maximum DGW not exceeding 5000kg. This includes dual purpose vehicles, motor caravans and ambulances.
Category M3 vehicle	A vehicle with four or more wheels used for the carriage of passengers, comprising more than 8 passenger seats in addition to the driver's seat and a maximum DGW exceeding 5000kg.
Category N1 vehicle	A vehicle with four or more wheels used for the carriage of goods and having a DGW not exceeding 3500kg.

## Introduction

Coach	A motor vehicle constructed or adapted to carry more than 16 seated passengers, with a DGW of more than 7,500kg and a maximum speed in excess of 60mph.
DGW	Design Gross Weight - The maximum gross weight that the vehicle was designed to operate at by the manufacturer. This is normally found on the manufacturer's plate fixed to the vehicle, or in the case of some older or heavier vehicles may be a 'Ministry Plate'. Such plates are not required on all vehicles.
DVSA	The Driver and Vehicle Standards Agency.
Immediately	Taking place without delay.
Large Class 4	A Class 4 vehicle with a DGW greater than 2500kg.
MAM	Maximum Authorised Mass – The maximum gross weight permissible in GB.
MIL	Malfunction Indicator Lamp
Minibus	A motor vehicle constructed or adapted to carry more than eight but no more than sixteen seated passengers (see also Bus).
Ministry Plate	Displays the maximum authorised weights at which a vehicle may be operated. This information supersedes the maximum weights displayed on the Manufacturer's plate.
Mol	Method of Inspection.
MOT Testing Guide	A handbook for MOT scheme administration available on-line at: <a href="https://www.gov.uk/topic/mot/manuals">https://www.gov.uk/topic/mot/manuals</a>
MOT Testing Service	The internet based system on which each test must be registered, from which MOT documentation is produced and to perform certain administrative functions.
OPTL	One Person Test Lane. These are lanes authorised by DVSA to conduct testing where the tester has the option of not using an assistant if so desired.
QC	Quality Control
SN	Special Notice - an official notice issued from time to time by DVSA to inform AEs, Testers and other system users of changes to the testing scheme. SNs may also be used to highlight areas of concern and to advise of developments of the scheme.
ULW	Unladen Weight - The weight of a vehicle inclusive of the body and all parts which are ordinarily used with the vehicle when working on a road. Unladen weight does not include the weight of water or fuel used for the propulsion of the vehicle, or of loose tools and loose equipment.
VT30	A notice of refusal of a MOT Test Certificate including the Welsh counterpart (VT30W).
VTS	Vehicle Testing Station.
V5/V5C	Vehicle registration certificate issued by the Driver and Vehicle Licensing Agency.

## Introduction

### 2. Application (Classes 3, 4, 5 and 7)

This Manual is a detailed guide to the inspection for statutory MOT testing of the following Classes:

Class 3	Three-wheeled vehicles not more than 450kg ULW (excluding motorcycle combinations) - Can be either category L2e or L5e.
Class 4	Three-wheeled vehicles more than 450kg ULW - Category L5e. Quadricycles - Can be either category L6e or L7e Cars and Taxis - Category M1 Minibuses, Motor Caravans, Dual Purpose Vehicles and Ambulances up to 12 passenger seats - Can be either category M1 or M2 American pick-ups Goods Vehicles not exceeding 3000kg DGW - Category N1
Class 5	Private passenger vehicles, Ambulances, Motor Caravans and Dual Purpose Vehicles with 13 or more passenger seats - Can be either category M2 or M3.
Class 7	Goods vehicles between 3001kg and 3500kg DGW inclusive - Category N1 (If a goods vehicle is presented with a manufacturer's plate and a 'Ministry plate' the weights to be used are those on the 'Ministry plate')

**Some Class 7 testing stations** are approved to test Class 5 vehicles with a DGW of no more than 5000kg referred to as Class 5L (category M2). Class 5L **does not** include any vehicle which is required to undergo a seatbelt installation check. Such vehicles must be presented at a Class 5A testing station.

Definitions of sub-Classes 4A and 5A are given in the MOT Testing Guide.

**Dual purpose vehicles** are defined in the MOT Testing Guide. This definition includes a requirement that the unladen weight does not exceed 2040kg. However, 4 x 4 pickup vehicles with a DGW over 3000kg up to and including 3500kg are to be considered dual purpose vehicles for test purposes where no unladen weight data is available.

**American pick-up** means a motor vehicle manufactured in the United States of America or Canada and:

- (a) is capable of carrying a driver and at least one passenger;
- (b) is capable of carrying goods in an open load bed separate from the driver/passenger compartment, with or without a removable cover; and
- (c) has a gross design weight over 3000kg but does not exceed 6500kg.

**Pick-up vehicles with a fifth-wheel** should not be considered articulated vehicles and tested as normal.

**To determine the seating capacity** of a passenger vehicle, the number of occupied wheelchairs that can be carried should be added to the number of seats.

**Other than for the inspection of tyres**, any two wheels of a vehicle shall be regarded as one wheel if the distance between the centres of the areas of contact between such wheels and the road surface is less than 460 mm.

Testers should be aware that this may affect the test Class; for example, a three wheeled vehicle with a wheel layout meeting this criterion must be tested as a motor bicycle.

## Introduction

### Tricycle and Quadricycle Test Classes

Vehicle Type	Description	Test Class
Three-wheeled moped (L2e)	Three wheeled vehicle with a max speed of <b>45km/h, not over 50cc</b> for a petrol engine <b>or 4KW for any other engine or electric motor, not more than 450kg ULW</b>	3
Motor Tricycle (L5e)	Three wheeled vehicle with wheels symmetrically arranged, a max speed <b>over 45km/h</b> , or engine size <b>over 50cc, not more than 450kg ULW</b>	3
Motor Tricycle (L5e)	Three wheeled vehicle with wheels symmetrically arranged with a max speed <b>over 45km/h</b> , or engine size <b>over 50cc, more than 450kg ULW</b>	4
Light Quadricycle (L6e)	Four wheeled vehicle with a max ULW of 350kg, max speed of <b>45km/h and not over 50cc for a petrol engine or 4KW for any other engine or electric motor.</b>	4
Quadricycle (L7e)	Four wheeled vehicle with a max ULW of 400kg (550kg for a goods vehicle) with a <b>max net power of 15KW.</b>	4

If any of the above vehicles are electrically powered, their unladen weight must not include the weight of the batteries.

If there is significant doubt about the power output or the weight of the vehicle, the presenter must provide documentary evidence.

### 3. Vehicles of historical interest (over 40 years old)

Some vehicles of historical interest may be exempt from Statutory MOT testing. Such vehicles must be over 40 years old, be registered as a vehicle of historical interest with DVLA and not be extensively modified.

Owners of these vehicles may still request a statutory test be conducted. In these circumstances, the test must be registered on the MOT Testing Service and carried out in the usual way, with the necessary documentation issued as appropriate.

Testers should take account of the fact that certain components on historic vehicles may have been manufactured to have a greater degree of play or tolerance than is found in modern vehicles.

Where a tester, or their assistant, is not familiar with the controls of a historic vehicle, the presenter should be asked to operate or demonstrate the controls if they are present.

### 4. Refusal to Test

Legislation permits testers to refuse to test vehicles in certain circumstances. Where any of these apply, the test should not be carried out and any fee paid for the test must be returned. It is therefore advisable to carry out certain pre-checks before starting the test, to ascertain that the general condition and suitability of the vehicle.

If the vehicle presenter requires written confirmation of why the test cannot be carried out, the test should be registered using the MOT Testing Service and a VT30 issued clearly showing the reason(s) why the test could not be carried out.

If reason to refuse 'i' applies, issue a hand written CT30 containing as many of the vehicle details as possible. A copy of the CT30 should be retained by the VTS.



## Introduction

### The reasons for refusing to carry out the test are:

- a. The log book / registration certificate or other evidence of the date of first use is not produced if the information therein, is necessary for the test to be carried out (Normally this evidence is only necessary if the vehicle has a 'cherished' registration mark or if the registration mark's year letter does not make clear the standard that should be applied; for example, the fitment of a hazard warning device on a vehicle first used on or after 1 April 1986).
- b. The vehicle or any part or equipment on the vehicle is so dirty that examination is unreasonably difficult.
- c. The vehicle is not fit to be driven when necessary to complete the test because of a lack of fuel, or oil, or for any other reason.
- d. The tester considers a load or other items, or insecurity of a load or other items, would prevent a proper test being carried out - unless the load is secured or removed.
- e. The VTS asks for the fee to be paid in advance and this is not done.
- f. The vehicle emits **substantial** quantities of **avoidable** smoke.
- g. A proper examination cannot be carried out because any door, tailgate, boot, engine cover, fuel cap or other device designed to be readily opened cannot be readily opened.
- h. The condition of the vehicle is such that, in the opinion of the tester, a proper examination would involve a danger of injury to any person or damage to the vehicle or other property.
- i. The vehicle has neither registration mark nor VIN/Chassis No./Frame No. by which it can be identified, or that all such identifications are illegible or use letters and numbers not normally used in the English language.

**If despite due care initially**, it becomes apparent during a test that the test cannot be completed for any of the above reasons, the test must be abandoned, or the vehicle failed because the test could not be satisfactorily completed. Any subsequent re-examination and fee must be in line with normal policy (see Fees and Appeals Poster).

In addition to this a tester must decline to test any vehicle that is not of a Class they are authorised to test or it is of such a size, weight or configuration it cannot be properly or safely tested on the approved facilities. There are, however, dispensations for narrow track vehicles as detailed at item 5.

### 5. Narrow Track Vehicles

If a vehicle has a track width that is too narrow for the vehicle to be safely tested on the approved pit or hoist, the inspection can be carried out on an area of hard standing within the testing facility. However, this only applies where the headlamp aim test can be conducted using the approved equipment and with the vehicle placed in the headlamp aim standing area.

The tester should use appropriate test methods covering all testable items set out in the Inspection Manual. For checks that require raising the wheels clear of the ground, a suitable jack should be used. Turning plate checks will need to be carried out on hard standing as best as possible.

If a roller/plate brake test cannot be carried out, due to the narrow track width or the transmission type, then a decelerometer test must be conducted.

If a tester has Health and Safety concerns regarding these procedures or the suitability of the test equipment, they should decline to test the vehicle.

### 6. Vehicle 'first used' Dates - Application of Test Criteria

Tester's will normally be provided with the vehicle details as part of the registration process. This will usually include the vehicle's 'first used' date. Where this information is available, the tester should only use defects applicable to the vehicle's age.

## Introduction

---

However, in cases where this information is not available or incorrect, the tester should determine the vehicle's 'first used' date as follows:

- a. Its date of manufacture, if the vehicle was originally used without being registered in GB, such as an imported vehicle or ex-HM Forces vehicle.
- b. Vehicles having a Q plate registration when presented for MOT are to be treated as follows:
  - for emission purposes only, they are to be considered as first used before 1 August 1975
  - for all other testing purposes they are to be considered as being first used on 1 January 1971
- c. In any other case, the earlier of either its date of first registration or the date six months after it was manufactured, for example; an anti-theft device is not required on vehicles first used before 1 September 2001. However, a vehicle first used after that date, but manufactured at least 6 months before that date (i.e. before March 2001) would still not require an anti-theft device to be fitted.

This information should be entered onto the MOT Testing Service to enable the tester to select the appropriate defects.

### 7. The Inspection Manual

Although this Manual is publicly available, it is specifically written for MOT Testers. It specifies the applications, procedures and standards to be used for MOT testing. It must be read in conjunction with any current Special Notices relevant to the Class or type of vehicle under test.

Testers should familiarise themselves with the contents of the Manual and any amendments to it, including SNs which affect test procedures or standards.

Defects found during the MOT test shall be categorised in one of the following groups:

- minor - defects having no significant effect on the safety of the vehicle or impact on the environment and other minor non-compliances. If only defects of a minor nature are present a test certificate will still be issued
- major - defects that may prejudice the safety of the vehicle, have an impact on the environment, put other road users at risk or other more significant non-compliances
- dangerous - defects constituting a direct and immediate risk to road safety or having an impact on the environment

### 8. Vehicle Technical Data

The MOT Testing Service may provide testers with technical information about certain vehicles under test. This is provided to assist testers regarding the test methods and/or standards to be applied.

### 9. The MOT Testing Guide

The MOT Testing Guide explains what is required of persons and organisations authorised to conduct statutory tests on certain motor vehicles. It also includes, amongst other things, information on the administration of the MOT scheme, disciplinary procedures and equipment calibration requirements.

### 10. Assessment of Component Condition

It is not practicable to lay down limits of wear and tolerances for all types of components on different models of vehicle, or to define acceptable amounts of damage, deterioration and effectiveness.

## Introduction

---

Testers are therefore expected to use their knowledge, experience and judgement in assessing whether the condition of a component has reached the stage where it is obviously adversely affecting its functionality or likely to adversely affect the roadworthiness of the vehicle.

### 11. Definition of Insecure

The term "insecure" is used many times throughout this Manual to describe a defective condition. This term should be taken to mean either:

- a component has relative movement (looseness) at its fixings where there should be none, or
- a component has relative movement (looseness) to an associated component where there should be none, or
- a safety critical component is not safely or completely attached at its fixing or to an associated component.

Certain components, such as wheel fixings, batteries, body mountings etc. have specific criteria detailed in the Manual.

### 12. Unsafe Modification

Modifications to vehicles must be assessed on their merits, taking account of the nature of the modification and whether the component is safety critical.

The main criteria to be used are:

- whether the modification adversely affects the roadworthiness of the vehicle, or
- is likely to cause injury (such as modification to the body), or
- has a disproportionately adverse effect on the environment.

### 13. Extensively Modified Vehicles

Where a vehicle has been extensively modified or converted, certain defects, such as for components 'missing where fitted as standard' should not be applied, for example:

- A car converted for competition rally use (i.e. rear seats removed, fitted with a roll cage and full harness seat belts etc.) may not be fitted with; brake servo, power steering, airbags etc.
- A car converted to a stretch limousine may no longer be fitted with items such as curtain airbags or a functional Electronic Stability Control system.

This exemption does not apply to vehicles with minor modifications. Therefore, a car fitted with rally style seats, body kit and a sports steering wheel would not be exempt from the requirement to have a driver's airbag where one was fitted as standard equipment.

**Vehicles modified for disabled use** must be assessed on their merits. For example, it is acceptable for the driver's airbag to be removed for a wheelchair user, but the SRS warning lamp must not indicate a system malfunction.

### 14. Inspection Procedure

Testers are advised to carry out pre-checks to ascertain the general condition and suitability of the vehicle for test. Other than when using a CT code, a test must not commence until the tester has registered the vehicle for test via the MOT Testing Service (see MOT Testing Guide).

When registering the vehicle for test, the actual details from the vehicle must be used. It is not acceptable to use details from other sources such as the V5C, job card, previous electronic record etc.

## Introduction

---

The tester who registered the vehicle for test must personally carry out the test, without avoidable distraction or interruption and only the tester is empowered to make decisions about the test results. Unless the test facility is approved for one person testing, the tester must use a suitable assistant for certain parts of the inspection.

The diagrams on pages 10 and 11 show a typical inspection routine which will aid the tester in making a thorough inspection of a vehicle. These routines may need to be varied to suit different test bay layouts and equipment types. It is recommended that the brake performance test is not carried out until after the rest of the inspection to prevent an unknown defect causing injury to a person, damage to the vehicle or other property.

It may be convenient to conduct the emissions test at the beginning of the inspection if the engine is still warm.

Small tools, such as pinch bars, levers and the Corrosion Assessment Tool must be used where necessary. A hand held inspection mirror may be used to facilitate the inspection but is not mandatory.

The MOT test must be carried out without dismantling, so it is not always possible to inspect some testable items. Bonnets, engine covers, luggage compartments, access flaps and passenger compartment doors must be opened where this is necessary to inspect testable items. If a bonnet, door, access panel etc. designed to be readily opened cannot be opened, so preventing access to a testable item, you must either abandon or refuse to carry out the test.

Testers are reminded to take care when jacking up vehicles to avoid causing damage, referring to manufacturers' information if available. Particular care is also needed when jacking vehicles fitted with pneumatic, hydraulic or self-levelling suspension.

Once the inspection is completed, the tester must record the test results using the MOT Testing Service (see MOT Testing Guide).

If testing under CT, brake efficiencies must be calculated by the tester and the readings retained for later data entry. All results should be recorded on the VT29 and any printout retained. Refer to the MOT Testing Guide for a full explanation of CT procedures.

### 15. Road Testing

The statutory test does not specifically include a road test of the vehicle. However, one is permitted if the tester considers it necessary to check the results of an inspection. The tester must be properly licensed to drive the vehicle and ensure the vehicle is in a safe condition to conduct the road test.

### 16. Disabled Driver's Controls

Where a disabled driver's control or fitment is additional to the standard driver's controls and does not adversely affect the standard vehicle equipment, they are not testable items. However, if any such equipment is seen to be defective, this should be reported to the vehicle presenter.

Disabled driver's controls or fitments that replace or affect the standard controls should be tested in the normal way and any defects should be recorded in the normal way.

### 17. Health and Safety

AEs and their staff are reminded of their obligation to adhere to all relevant Health and Safety legislation while MOT testing. Further advice can be obtained from your local Health and Safety Enforcement Officer or Local Authority Environmental Health Officers as appropriate.

Additional care should be taken when testing electric and hybrid vehicles as:

- there may be high voltage present at any one of several points around the vehicle, including storage capacitors and batteries
- on hybrid vehicles, the engine may start without warning when electrical equipment is operated or if the battery voltage drops

## Introduction

### 18. Recording Defects

Defects within this Manual are selected using the MOT Testing Service, via a component-based menu system. The User will first select the appropriate component from the main component list and then make further selections from the sub-menu(s). Once the appropriate component has been selected, a list of defects will be available for selection.

Various categories of defect may be available for the same item depending on the nature or severity of the defect i.e. minor, major or dangerous. The tester must select the appropriate category, being guided by the defect wording and using their knowledge, experience and judgement.

Where an item is not sufficiently deteriorated to justify rejection, there may be an option to select 'advisory' to inform the presenter of this fact.

Where only defects categorised as being of a minor nature have been selected, a test certificate will still be issued. Unlike advisory items, the use of Minor defects, where appropriate, is mandatory.

Testers may consider that a defect on a non-testable item constitutes a dangerous defect, in which case this fact should be clearly explained to the vehicle presenter.

Some defects listed in the Inspection Manual may not be accessible if they are not relevant due to the age or test Class of the vehicle under test. However, advisory items (if appropriate) for these defects may still be selectable.

### 19. Retest Following Failure

Information on retest fees and procedures can be found in the current MOT Testing Guide and on the VT9A - Fees and Appeals poster.

When carrying out a partial retest the tester must examine:

- all the previously failed item(s)
- any item(s) that may have been affected by the repairs
- any minor defect or item advised on at the time of the initial test

If during a retest it is clear that any defect is present which would mean the issue of a test certificate is not justified, a further VT30 must be issued.

### 20. Recommended Inspection Routine

#### Topside

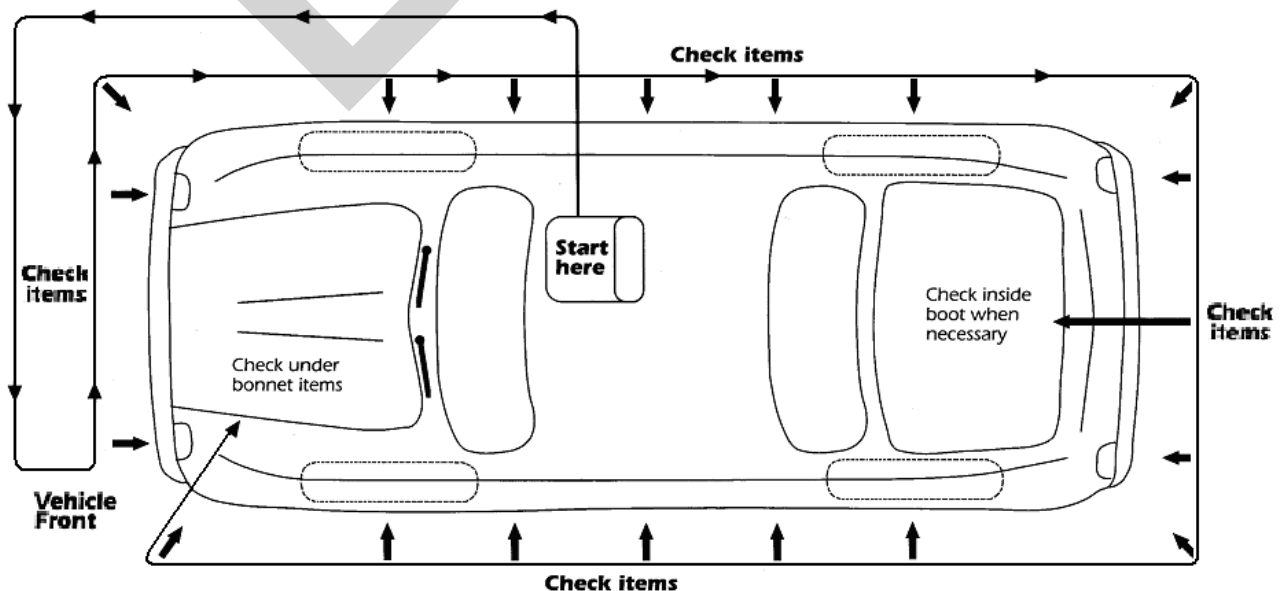

## Introduction

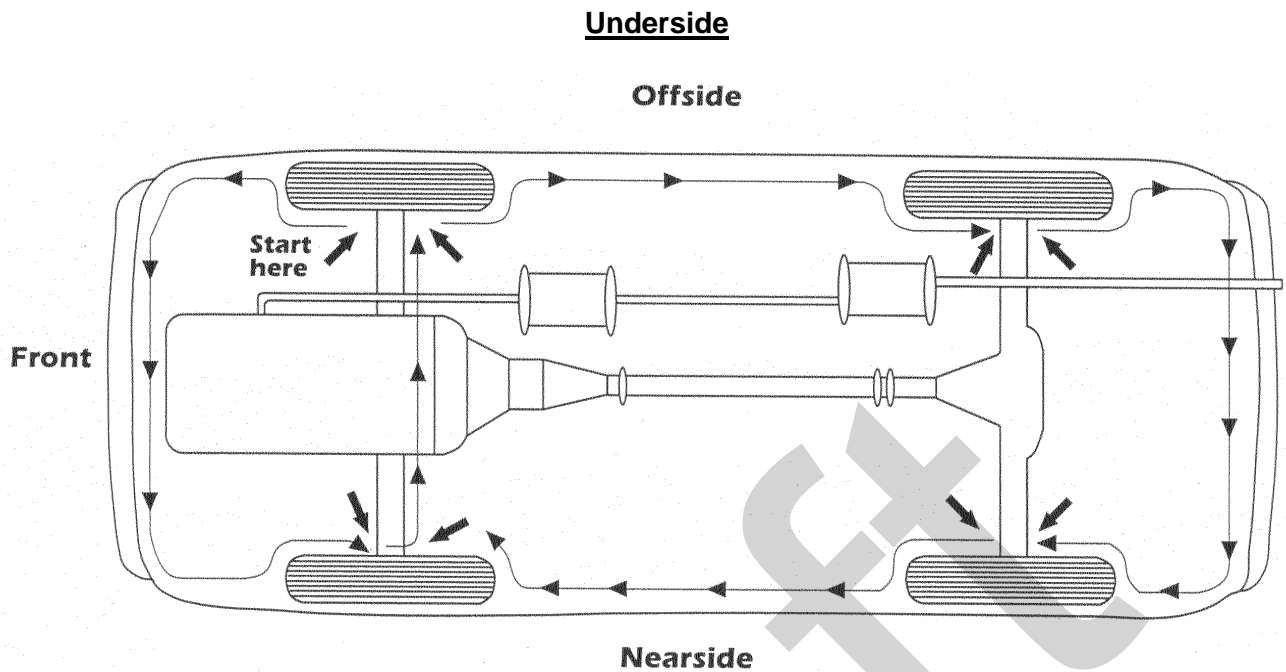

### Operations

1. With the wheels in the straight ahead position and supporting the vehicle weight, inspect the vehicle underside following the routine shown. If using a lift for the underside inspection, it is recommended that the rear wheels are chocked whilst the lift is raised.
2. Jack up the front and rear wheels to check relevant items (Rear wheel jacking not applicable to Class 5 vehicles or Class 4 vehicles with a DGW exceeding 5000kg).
3. Carry out the headlamp aim check and brake performance test at a convenient point in the routine depending on the layout of the equipment.

# 0 Identification of the Vehicle

---

## Section 0 - Contents

- 0.1 Registration Plates
- 0.2 Vehicle Identification Number (VIN)

Draft

# 0 Identification of the Vehicle

## 0.1 Registration plates

**This inspection applies to** all vehicles other than unregistered, foreign registered, diplomatic or military vehicles.

**A three-wheeled vehicle** which does not have a body of a type which is characteristic of the body of a four-wheeled vehicle does not require a front number plate. All other vehicles, including quadricycles, must be fitted with front and rear registration plates, which must both be checked to ensure the registration number displayed is the same.

**A registration plate should be rejected** if it fails to meet any of the requirements detailed below. The inspection does not include the suppliers name, postcode, BS number or any logos or emblems outside of the minimum margin around the registration number.

**Testers are not required to physically measure** the characters or their spacing and they should only be rejected if they are obviously incorrect.

### Registration plates must not:

- Be obscured, excessively damaged, deteriorated or delaminated.
- Have background overprinting.
- Have any feature that has the effect of changing the appearance or legibility of any of the characters.
- Use fixing screws or bolts that are positioned so as to change the appearance or legibility of any of the characters.
- Have a honeycomb or similar effect background on vehicles first registered on or after 1 September 2001 (back lit registration plates may have a honeycomb type construction which is not to be confused with a honeycomb effect background).

**Particular attention should be given to the position of any fixing screws or bolts as well as any delamination** of the number plate as this can prevent identification of the vehicle by automatic number plate recognition (ANPR) cameras which 'see' any non-reflective material as being black.

### Registration plates may:

- Have an optional non-reflective border displayed within the margin provided it is no wider than 6mm and not within 5mm of the characters.
- Display white, grey or silver characters on a black background on vehicles manufactured before 1 January 1977.

### Registration plate characters:

- May contain grey, possibly to achieve a 3D effect.
- Must be the correct size, stroke width and spacing (see page 3).
- Must not be italic, sloping or formed using broken or multiple strokes.
- Must be laid out in the correct format for the age of vehicle (see page 3).
- Must be formed using the prescribed font or be substantially similar to the prescribed font (as shown below).

**I234567890**  
**ABCDEFGHIJKLMN OPQRSTUVWXYZ**



# 0 Identification of the Vehicle

Registration plates fitted to vehicles manufactured on or after 1 January 1977 must:

- Have black characters on a white background when fitted to the front.
- Have black characters on a yellow background when fitted to the rear.
- Be fitted vertically, or as close to vertical as is reasonably practicable.

Registration plates may be in a single or two line formats. Additionally, a three line format is permitted on vehicles first used before 1 September 2001.

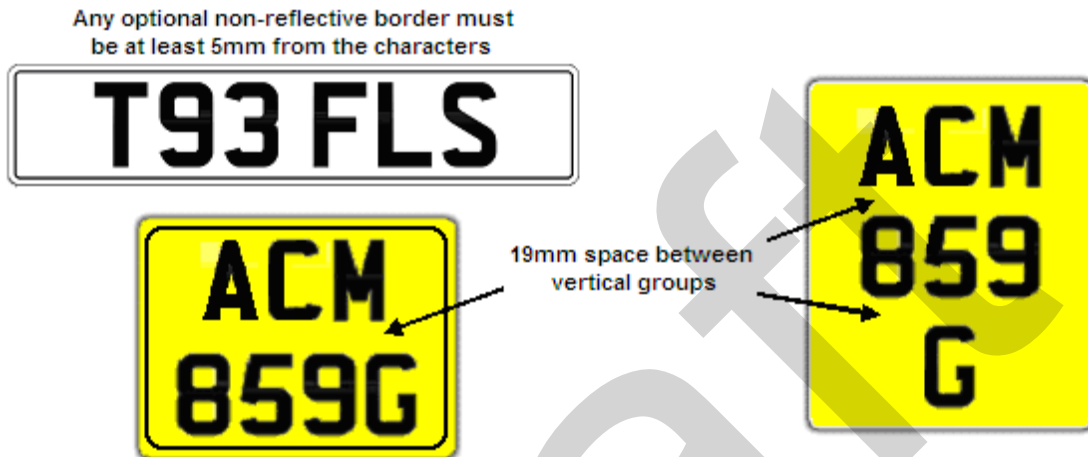

Registration plates must meet the dimensional requirements shown in the examples; however, the space between a '1' or an 'l' and another character is permitted to be proportionately greater.

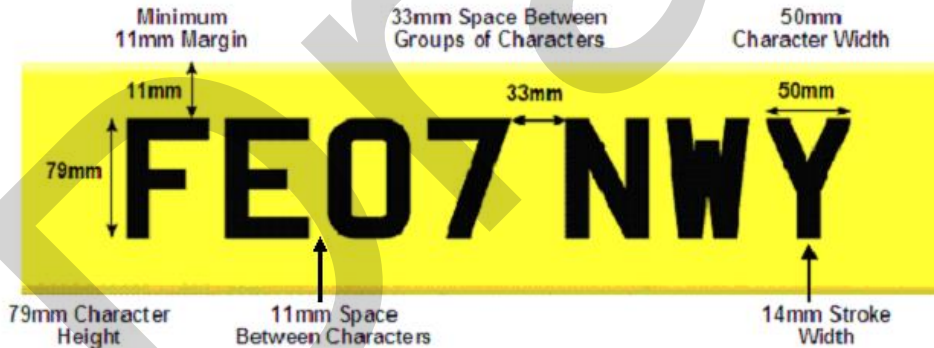

Larger plates may be fitted to some vehicles registered before 1 September 2001 with characters 89mm high and other relevant dimensions that are subsequently larger.

Smaller registration plates are acceptable on imported vehicles of a design that cannot accommodate standard size registration plates.

Vehicles with non-date related plates, such as those issued before 1963 and Northern Ireland plates must still meet the separation requirement between groups of characters where relevant.

Defect	Category
(a) Number plate missing or so insecure that it is likely to fall off.	Major
(b) Number plate inscription missing or illegible.	Major
(c) Number plate showing an incorrect registration	Major
(d) Number plate does not conform to the specified requirements.	Major

# 0 Identification of the Vehicle

## 0.2 Vehicle Identification Number (VIN)

Check the vehicle is displaying a legible Vehicle Identification Number.

A Vehicle Identification Number (VIN or chassis number) is required on:

- kit cars and amateur built vehicles first used on or after 1 September 2001
- all other vehicles first used on or after 1 August 1980.

**Vehicles may have the VIN displayed** in more than one location, but only one VIN is required to be complete and legible.

**Multi-stage build vehicles** can have two VINs, both of which may have the same last 8 digits.

In these circumstances, when registering the vehicle for test, enter the last 6 digits of either VIN, along with the registration number. If the MOT Testing Service finds a match against either full VIN this should be accepted.

If no match is found, create a new record using the converters VIN.

**A converters serial number** is not a VIN.

Defect	Category
(a) VIN missing or cannot be found.	Major
(b) VIN incomplete, illegible or obviously falsified.	Major

# 1 Brakes

## Section 1 - Contents

### 1.1 Condition and Operation

- 1.1.1 Service brake pedal or hand lever pivot
- 1.1.2 Service brake pedal or hand lever condition and travel
- 1.1.3 Air and vacuum systems
- 1.1.4 Low pressure warning
- 1.1.5 Hand operated brake control valve
- 1.1.6 Parking brake lever or control
- 1.1.7 Brake valves
- 1.1.8 Not in use
- 1.1.9 Pressure storage reservoirs
- 1.1.10 Brake servo units and master cylinder (hydraulic systems)
- 1.1.11 Rigid brake pipes
- 1.1.12 Flexible brake hoses
- 1.1.13 Brake linings and pads
- 1.1.14 Brake discs and drums
- 1.1.15 Brake cables, rods, levers and linkages
- 1.1.16 Brake actuators (including spring brakes, hydraulic cylinders and callipers)
- 1.1.17 Load sensing valve
- 1.1.18 Brake slack adjusters
- 1.1.19 Endurance braking system (where fitted)
- 1.1.20 Not in use
- 1.1.21 Complete braking system

### 1.2 Service Brake Performance and Efficiency

- 1.2.1 Performance
- 1.2.2 Efficiency

### 1.3 Secondary Brake Performance and Efficiency

- 1.3.1 Performance
- 1.3.2 Efficiency

### 1.4 Parking Brake Performance and Efficiency

- 1.4.1 Performance
- 1.4.2 Efficiency

### 1.5 Additional Braking Device (Retarder) Performance

### 1.6 Anti-lock Braking System (ABS)

### 1.7 Electronic Braking System (EBS)

### 1.8 Brake Fluid

# 1 Brakes

## 1.1 Condition and Operation

### 1.1.1 Service brake pedal or hand lever pivot

Defect	Category
(a) Pivot too tight.	Major
(b) Excessive wear or free play.	Major

### 1.1.2 Service brake pedal or hand lever condition and travel

A **brake pedal** with grooves or raised sections to provide grip in wet conditions should be rejected if it is worn smooth. However, some vehicles may have been manufactured with a brake pedal pad which did not incorporate grooves or the fitting of an anti-slip material and these should not be rejected.

**More commonly, a brake pedal rubber** will be fitted and this is considered to be an anti-slip material in itself. It is therefore not regarded as a defect if the design pattern is worn smooth.

A **vehicle should only be failed** for insufficient reserve if the pedal or lever is touching the floor/handlebar. Checks on vehicles with power-assisted braking systems should be carried out with the engine off.

**It may be possible on motorcycle derived systems** for the brake lever to touch the handlebar. In such cases the extent of reserve travel should be assessed during the brake test.

Defect	Category
(a) Insufficient reserve travel.	Major
(b) Service brake control:	
(i) not releasing correctly	Minor
(ii) not releasing correctly and functionality of brakes affected.	Major
(c) Anti-slip provision missing, loose or worn smooth.	Major

### 1.1.3 Air and vacuum systems

**This inspection does not apply to** vehicles first used before 1 October 1937.

A **vehicle with an ULW not more than 3050kg**, with a reservoir coupled direct to the induction manifold, or a reservoir integral in a servo unit, is not necessarily required to be fitted with a warning device.

**To check the build-up of air or vacuum**, completely empty the reservoir by repeatedly pressing the service brake pedal. Start the engine and run it at just below the governed speed if diesel or 2000 rpm if petrol. The warning device must stop operating within 3 minutes for pressure systems and 1 minute for vacuum systems.

**For checks that require reference to a pressure or vacuum gauge** warning mark, but no warning mark is present, the following reference values should be used:

- 45psi (3.1kg/sq cm or 3 bar) for a pressure gauge
- 10" to 12" (25 to 30cm) for a vacuum gauge.

# 1 Brakes

Defect	Category
(a) Insufficient pressure/vacuum assistance for less than: (i) four brake applications after the warning device has operated (or gauge shows an unsafe reading) (ii) two brake applications after warning device has operated (or gauge shows an unsafe reading).	Major  Dangerous
(b) Time taken to build up air pressure/vacuum to safe working value not in accordance with the requirements .	Major
(c) Repeated operation of any ancillary air or vacuum system completely depletes the stored air or vacuum for the braking system.	Major
(d) Air leak causing a noticeable drop in pressure or audible air leak.	Major
(e) External damage likely to affect the function of the braking system.	Major

## 1.1.4 Low pressure warning

**This inspection does not apply to** vehicles first used before 1 October 1937.

**A vehicle with an ULW not more than 3050kg** with a reservoir coupled direct to the induction manifold, or a reservoir integral in a servo unit, is not necessarily required to be fitted with a warning device.

**Warning devices may be visual or audible** but only one needs to work if both are fitted.

**Some vehicles with full power hydraulic braking systems** will illuminate the low pressure warning light as soon as the ignition is switched on. In these circumstances it is not a defect unless the warning light stays on after the engine has been started.

Defect	Category
(a) Low pressure warning gauge or indicator: (i) malfunctioning or defective (ii) not identifying low pressure.	Minor  Major

## 1.1.5 Hand operated brake control valve

**This inspection applies to** all vehicles with a secondary brake operating mechanism in addition to, or in place of, the normal parking brake lever.

Defect	Category
(a) Control cracked, damaged or excessively worn.	Major
(b) Control insecure on valve or valve insecure.	Major
(c) Loose connections or leaks in the system.	Major
(d) Malfunctioning.	Major

## 1.1.6 Parking brake lever or control

**A parking brake is not required** on vehicles first used before 1906.

**Some defects in this sub-section** may not apply to the type of parking brake fitted.

**A parking brake lever** must obviously have excessive travel before being rejected.

# 1 Brakes

An **Electronic Parking Brake (EPB)** may apply automatically in certain conditions, such as when the ignition is switched off or when the driver's door is opened. Testers may need to take account of this throughout various aspects of the test.

**Quadricycles** may be fitted with one of the following types of parking brake:

- a handlebar mounted over-centre lever
- a gear lever which, when moved into the park position, operates a cable via a linkage attached to the lever
- a transmission lock by selecting the 'P' position on machines with CVT transmission.

These machines are type approved and should not therefore be rejected for design features which prevent them from meeting the stated requirements.

Where the parking brake uses the 'P' position on the gearbox, the efficiency of the brake cannot be tested. The tester must therefore make the best assessment possible, by using a gradient (ideally 16%), where one is available, or by attempting to push the machine when 'P' is selected.

The over-centre lever type can be brake tested as normal using one of the approved test methods.

Defect	Category
(a) Ratchet not holding correctly.	Major
(b) Parking brake lever pivot or ratchet mechanism:	
(i) obviously worn	Minor
(ii) worn to the extent that the brake may inadvertently release.	Major
(c) Parking brake lever has excessive movement indicating incorrect adjustment.	Major
(d) Parking brake control missing, defective or inoperative.	Major
(e) Electronic parking brake MIL indicates a malfunction.	Major

## 1.1.7 Brake valves

Defect	Category
(a) Valve:	
(i) damaged or excessive air leak	Major
(ii) leaking such that brake functionality is affected.	Dangerous
(b) Excessive oil discharge from a compressor or brake valve.	Minor
(c) Valve insecure or inadequately mounted.	Major
(d) Hydraulic fluid:	
(i) leak from a brake valve	Major
(ii) leak from a brake valve such that brake functionality is affected.	Dangerous

## 1.1.8 Not in Use

## 1.1.9 Pressure storage reservoirs

**This inspection applies to** air and air/hydraulic braking systems on vehicles first used from 1 October 1937.

# 1 Brakes

Defect	Category
(a) Reservoir:	
(i) has minor damage or corrosion	Minor
(ii) heavily damaged, heavily corroded or leaking.	Major
(b) Drain device on an air brake system:	
(i) operation affected	Minor
(ii) inoperative.	Major
(c) Reservoir insecure or inadequately mounted.	Major

## 1.1.10 Brake servo units and master cylinders (hydraulic systems)

**Hydraulic brake fluid level** checks are confined to transparent reservoirs or where an indicator is fitted; reservoir caps should not be removed.

**A brake fluid warning lamp** may be a combined lamp for other aspects, such as worn brake pads or to indicate that the parking brake is applied. The inspection of the brake fluid warning lamp does not apply to Class 3 vehicles.

Defect	Category
(a) Brake servo:	
(i) defective or ineffective	Major
(ii) inoperative.	Dangerous
(b) Master cylinder:	
(i) defective but brake still operating	Major
(ii) leaking.	Dangerous
(c) Master cylinder insecure.	Major
(d) Brake fluid:	
(i) below minimum mark	Minor
(ii) significantly below minimum mark	Major
(iii) not visible.	Dangerous
(e) Master cylinder reservoir cap missing.	Major
(f) Brake fluid warning light illuminated or defective.	Minor
(g) Incorrect functioning of brake fluid level warning device.	Minor

## 1.1.11 Rigid brake pipes

**To correctly assess the condition** of corroded metal brake pipes, surface dirt may have to be removed. In these circumstances, it is permissible to lightly scrape the pipe with a specialist brake pipe corrosion tool or the Corrosion Assessment Tool 'spade end', but care must be taken not to damage any protective coating.

**Chafing, corrosion or damage** to a rigid brake pipe so that its wall thickness is reduced by 1/3 (approximately 0.25 mm for typical hydraulic brake pipe) justifies rejection, although it is accepted that this is not easy to determine. If there is doubt as to whether the pipe is sufficiently deteriorated to justify rejection, the benefit of the doubt should be given.

# 1 Brakes

Defect	Category
(a) Brake pipe is at imminent risk of failure or fracture.	Dangerous
(b) Leaking brake pipe or connection: <ul style="list-style-type: none"> <li>(i) on an air brake system</li> <li>(ii) on a hydraulic systems.</li> </ul>	Major Dangerous
(c) Brake pipe damaged or excessively corroded.	Major
(d) Brake pipe: <ul style="list-style-type: none"> <li>(i) inadequately clipped or supported</li> <li>(ii) likely to become detached or damaged.</li> </ul>	Minor Major

## 1.1.12 Flexible brake hoses

**A hose should only be considered excessively damaged** or chafed if it is severe enough to expose the reinforcement.

Defect	Category
(a) Brake hose damaged and likely to fail.	Dangerous
(b) Flexible brake hose: <ul style="list-style-type: none"> <li>(i) Slightly damaged, chafed or twisted</li> <li>(ii) excessively damaged, chafed, twisted or stretched.</li> </ul>	Minor Major
(c) Brake hoses or connections leaking on: <ul style="list-style-type: none"> <li>(i) air brake systems</li> <li>(ii) hydraulic systems.</li> </ul>	Major Dangerous
(d) Brake hose bulging under pressure.	Major
(e) Brake hose porous	Major

## 1.1.13 Brake linings and pads

**Some vehicles have a warning light** on the dashboard to indicate that the brake pads are becoming excessively worn. This lamp may be a multi-function lamp which also illuminates for other reasons, such as the handbrake being applied. Tester's must therefore ensure that the lamp is not illuminated for any other reason before failing for its illumination.

Defect	Category
(a) Brake lining or pad: <ul style="list-style-type: none"> <li>(i) wear indicator illuminated</li> <li>(ii) worn below 1.5mm</li> </ul>	Major Dangerous
(b) Brake lining or pad contaminated with oil, grease etc.	Major
(c) Brake lining or pad missing or incorrectly mounted.	Dangerous



# 1 Brakes

## 1.1.14 Brake discs and drums

A brake disc or drum must be obviously significantly worn before rejection is justified. Being worn below the manufacturer's recommended limits is not reason in itself.

Defect	Category
(a) Brake disc or drum:	
(i) significantly and obviously worn	Major
(ii) insecure, fractured or otherwise likely to fail.	Dangerous
(b) Contaminated with oil, grease etc.	Major
(c) Missing.	Dangerous
(d) Brake drum back plate insecure.	Major

## 1.1.15 Brake cables, rods, levers and linkages

Defect	Category
(a) Cable damaged or knotted.	Major
(b) Component excessively worn or corroded.	Major
(c) Cable, rod or joint insecure.	Major
(d) Cable guide defective affecting operation.	Major
(e) Restriction in free movement of the braking system.	Major
(f) Abnormal movement of levers indicating maladjustment or excessive wear.	Major

## 1.1.16 Brake actuators (including spring brakes, hydraulic cylinders and callipers)

Defect	Category
(a) Actuator cracked or damaged and:	
(i) braking performance not affected	Major
(ii) braking performance affected.	Dangerous
(b) Actuator leaking and:	
(i) braking performance not affected	Major
(ii) braking performance affected.	Dangerous
(c) Actuator insecure or inadequately mounted and:	
(i) braking performance not affected	Major
(ii) braking performance affected.	Dangerous
(d) Actuator:	
(i) excessively corroded	Major
(ii) excessively corroded and likely to crack.	Dangerous
(e) Actuator has:	
(i) excessive travel of operating system indicating need for adjustment	Major
(ii) no reserve travel and braking performance affected.	Dangerous

# 1 Brakes

## 1.1.17 Load sensing valve

Defect	Category
(a) Load sensing valve linkage defective.	Major
(b) Load sensing valve linkage obviously incorrectly adjusted.	Major
(c) Load sensing valve seized or inoperative and: <ul style="list-style-type: none"> <li>(i) ABS functioning</li> <li>(ii) ABS not fitted or inoperative.</li> </ul>	Major Dangerous
(d) Load sensing valve missing where fitted as standard.	Dangerous

## 1.1.18 Brake slack adjuster

Defect	Category
(a) Adjuster damaged, seized or having abnormal movement, excessive wear or incorrect adjustment.	Major
(b) Adjuster defective.	Major
(c) Incorrectly installed.	Major

## 1.1.19 Endurance braking system

**An endurance braking system** e.g. exhaust brake or electronic retarder is only likely to be fitted to some large motor caravans and category M2 and M3 vehicles.

Defect	Category
(a) Endurance braking system connectors or mountings: <ul style="list-style-type: none"> <li>(i) insecure</li> <li>(ii) insecure and functionality affected.</li> </ul>	Minor Major
(b) Endurance braking system obviously defective.	Major

## 1.1.20 Not in use

## 1.1.21 Complete braking system

Check the strength and continuity of the vehicle's load bearing members and their supporting structure or panelling around any braking component mounting.

Guidance for assessing corrosion and use of the corrosion assessment tool is provided at Appendix 'A'.

# 1 Brakes

Defect	Category
(a) Other braking system (e.g. antifreeze pump, air dryer etc.) component damaged or corroded: (i) to the extent that the braking system is adversely affected (ii) to the extent that braking performance is affected.	Major Dangerous
(b) Air or antifreeze: (i) leaking (ii) leaking and system functionality adversely affected.	Minor Major
(c) Any braking system component insecure or inadequately mounted.	Major
(d) Braking system component modification: (i) unsafe (ii) adversely affecting braking performance.	Major Dangerous
(e) The strength or continuity of the load bearing structure within 30cm of any braking system actuation component mounting (a prescribed area): (i) is significantly reduced (see Appendix A) (ii) is so weakened that the functionality of the braking system is affected.	Major Dangerous

## 1.2 Service Brake Performance and Efficiency

### 1.2.1 Service Brake Performance

**You must ensure** that the vehicle is in such a condition that the test can be carried out safely.

**Where the primary brake tester is not suitable** for the vehicles drive configuration, transmission type or braking system, a full or partial decelerometer test may be appropriate. Additional information available from the vehicle manufacturer should also be taken into account.

**When conducting a test on an RBT** where more than half of the wheels of a brake system lock the efficiency requirements for that system are considered to be met.

Alternatively if the front wheels lock on the service brake of an unladen Class 7 vehicle and at least a 100kg force at each rear wheel for a two axle vehicle or at least 50kg force on a three axle vehicle the efficiency is also considered to be met.

**Vehicles of unknown test weight** can be tested on either an RBT or PBT. However, if the number of wheel locks are not achieved for any system on a non-ATL RBT, a decelerometer test must be used to establish the overall brake efficiency of the relevant system(s).

**Certain converted passenger vehicles**, such as motor caravans, ambulances etc., may have a kerb weight greatly in excess of the base model weight displayed by the MOT Testing Service. In these circumstances, the vehicle should be treated as having an unknown test weight.

**Some tricycles with two brake controls** may have a linked braking system. The brake force used in the efficiency calculation is the total from all wheels when operated by that control only.

**Additional braking devices**, such as electronic retarders, should not be operative during the brake test.

#### Using a Roller Brake Tester

Ensure that the vehicle, or system, under test is suitable for testing using a roller brake tester. Where the vehicle or system is unsuitable, it should be tested using decelerometer.

# 1 Brakes

## ATL Test Procedure

ATL approved test stations should position the front wheels of the vehicle in the rollers of the brake tester and follow the sequence of instructions as displayed and prompted on screen. Where a vehicle is ejected from the brake rollers, the required brake efforts may not be achieved. In these circumstances, the test should be repeated in manual mode, running each roller individually.

## Non - ATL Test Procedure

**Testers are permitted** to use an alternative procedure to that specified below so long as all the testable elements are adequately covered.

1. Position the wheels of the first axle to be tested in the brake rollers and then run both sets of rollers together in a forward direction until the vehicle is aligned. With the rollers still running, note whether a significant brake effort is recorded from any wheel without a brake being applied.
2. Gradually apply the service brake and watch how the braking effort for each wheel increases. Stopping short of lock up or maximum effort, hold a steady pedal pressure and check there is no excessive brake effort fluctuation with each revolution of the road wheel.
3. Gradually release the service brake and observe how the braking effort at each wheel reduces.
4. Gradually depress the service brake again, this time until maximum effort is achieved, or until the wheel locks and slips on the rollers. Stop the rollers.
5. Record the reading at which the maximum braking effort is achieved and whether "lock-up" occurs. Stop the rollers if they have not stopped automatically.
6. Place the wheels of the next axle in the brake rollers and repeat the above procedure.

When checking maximum effort, testers can elect to run the brake rollers individually or together, depending on the suitability of the RBT. However, if the rollers are run together and the vehicle fails to meet the minimum performance requirement, the test must be repeated running the rollers individually.

If both rollers are run together, it will almost certainly be necessary to chock the wheels not under test.

## Using a Plate Brake Tester

For vehicles other than Class 7, establish the actual presented weight of the vehicle.

For Class 7 vehicles, the brake efficiency will be calculated using either:

- the actual DGW where the presented weight is at least 2000kg (the DGW is obtained from the manufacturer's plate fitted to the vehicle), or
  - a nominal DGW figure of 2600kg if the presented weight is less than 2000kg.
1. Enter the appropriate data to conduct the test.
  2. For each check, drive the vehicle forwards at a steady speed of about 4mph up to the plate tester
  3. On the first run, just before the wheels are on the plate high friction surfaces, apply a light constant pressure to the brake pedal. Do not stop on the tester. Note the way in which the brake efforts fluctuate.
  4. On the second run, as soon as the wheels are on the plate high friction braking surfaces, apply the service brake progressively until maximum effort is achieved.
  5. Note the way in which the brake efforts increase and the maximum values achieved.

If a vehicle fails any aspect of the plate brake test, the check should be repeated to confirm the result.

## Using a Decelerometer

**If the vehicle or system is of a type** which cannot be tested on a roller brake tester, set up the decelerometer in the vehicle in accordance with the equipment manufacturer's instructions

# 1 Brakes

1. Drive the vehicle on a level road at a steady speed of approximately 20mph (32kph) and progressively apply the service brake to maximum.
2. Note whether the vehicle or steering pulls severely one way and the brake efficiency recorded.

Before carrying out a decelerometer test on the public highway, testers must ensure they are suitably qualified to drive the vehicle and familiar with the controls. For vehicles with special controls, such as disabled vehicles, the presenter should be allowed to drive during the test if he/she wishes.

## Calculating Brake Imbalance

For the majority of vehicles, the MOT Testing Service will calculate brake imbalance automatically. However, where this is not the case, such as for tricycles and quadricycles, or if MTS is not working, brake imbalance is calculated against the maximum brake efforts on each axle as follows:

$$\frac{\text{Higher brake effort} - \text{Lower brake effort}}{\text{Higher brake effort}} \times 100 = \% \text{ Imbalance}$$

**Disregard any brake imbalance** across an axle if the lower recorded effort is as a result of a locked wheel or if the higher brake effort from a wheel is not more than 40kg.

**The check for rear axle brake imbalance** does not apply to tricycles or quadricycles.

Defect	Category
(a) Braking effort:	
(i) inadequate at a wheel	Major
(ii) not recording at a wheel.	Dangerous
(b) Brakes imbalance across an axle such that:	
(i) the braking effort from any wheel is less than 70% of the maximum effort recorded from the other wheel on the same axle. Or in the case of testing on the road, the vehicle deviates excessively from a straight line	Major
(ii) the braking effort from any wheel is less than 50% of the maximum effort recorded from the other wheel on a steered axle.	Dangerous
(c) A brake on any wheel grabbing severely.	Major
(d) Abnormal lag in brake operation on a wheel.	Major
(e) Excessive fluctuation in brake effort through each wheel revolution.	Major
(f) Significant brake effort recorded with no brake applied indicating a binding brake.	Major
(g) Brake performance unable to be tested	Major

### 1.2.2 Service Brake Efficiency

#### Calculating Brake Efficiency

For the majority of vehicles, the MOT Testing Service will calculate brake efficiencies automatically.

If MTS is not working; add the brake efforts from each wheel for the system under test and carry out the following calculation:

$$\% \text{ Efficiency} = \frac{\text{Total Brake Effort}}{\text{Vehicle Test Weight}} \times 100$$

**The Vehicle Test Weight** will depend on the vehicle test Class as follows:

- Classes 3 and 4; use the presented weight when this is provided by the brake test equipment. Otherwise, the weight taken from a weight data chart or some other reliable source.

# 1 Brakes

- Class 7; the DGW taken from the manufacture's plate or, the nominal DGW of 2,600kg if using a plate brake tester and the presented weight is less than 2000kg.
- Class 5; the lesser of the DGW or MAM taken from the manufacturer's plate. On vehicles where only the ULW is displayed, the DGW must be calculated by multiplying the number of passenger seats by 63.5kg (or 140lbs) and adding the ULW; for example:  
52 seats x 63.5kg = 3302kg + 5,250kg ULW = 8552kg.

**Table of efficiency requirements**

M1 vehicles having a service brake operating on at least 4 wheels and which were first used: <ul style="list-style-type: none"> <li>• On or after 1 September 2010</li> <li>• Before 1 September 2010</li> </ul>	58% 50%
N1 vehicles	50%
M2 and M3 vehicles having a service brake operating on at least 4 wheels which were first used: <ul style="list-style-type: none"> <li>• On or after 1 January 1968</li> <li>• Before 1 January 1968.</li> </ul>	50% 45%
L2e and L6e vehicles with a single service brake control that operates the brakes on all wheels.	40%
L5e vehicles with a single service brake control that operates the brakes on all wheels which were first used: <ul style="list-style-type: none"> <li>• On or after 1 January 1968</li> <li>• Before 1 January 1968.</li> </ul>	50% 40%
L7e vehicles with a single service brake control that operates the brakes on all wheels.	50%
Vehicles first used before 1 January 1968 which do NOT have one means of control operating on at least 4 wheels and which have one brake system with two means of control or two brake systems with separate means of control.	30% from 1 <sup>st</sup> means of control
Any L category vehicle with two service brake systems each having a separate means of operation.	25% from 2 <sup>nd</sup> means of control
Vehicles first used before 1 January 1915 only require one efficient braking system.	No specific requirement

## Brake Test Results

Brake efforts achieved during a test should be entered on the MOT Testing Service as follows:

- Roller brake tests - enter the brake effort from each wheel and whether 'lock-up' occurs. The MOT Testing Service will then automatically calculate brake efficiency and out of balance results. Other defects must be entered manually by the tester.
- Plate brake tests - enter the brake effort from each wheel. The MOT Testing Service will then automatically calculate brake efficiency and out of balance results. Other defects must be entered manually by the tester.
- Decelerometer tests - enter the efficiencies recorded by the meter. The MOT Testing Service will automatically pass or fail the vehicle in respect of brake efficiency, but other defects must be entered manually by the tester.

**Where the MOT Testing Service is unavailable**, refer to the latest edition of the MOT Testing Guide.

# 1 Brakes

In cases where the required brake efficiency is only just met, but the tester knows that a higher performance figure is normally obtained for the vehicle type, the presenter should be informed.

Defect	Category
(a) Service brake efficiency:	
(i) below minimum requirement	Major
(ii) less than 50% of the required value.	Dangerous

## 1.3 Secondary brake performance and efficiency

### 1.3.1 Secondary Brake Performance

**This inspection only applies to vehicles with a single line braking system.**

The secondary brake control may be the parking brake lever, or a separate brake control.

Where the secondary brake is also the parking brake then there is no need to carry out a separate park brake test.

To avoid possible damage when testing transmission parking brakes, the minimum secondary brake efficiency requirement must be calculated before the brake is tested and testing of the brake must cease as soon as the minimum efficiency requirement is reached.

#### Using a Roller Brake Tester

1. On each axle which has a secondary brake fitted, run the rollers and gradually apply the secondary brake keeping any "hold-on" button or trigger in the disengaged position the whole time, watching how the braking effort for each wheel increases.
2. Continue to apply the parking brake until maximum effort is achieved, or until the wheels lock and slip on the rollers.
3. Record the reading at which the maximum braking effort is achieved and whether "lock-up" occurs. Stop the rollers if they have not stopped automatically.

#### Using a Plate Brake Tester

1. Drive the vehicle forwards at a steady speed of about 4mph up to the plate tester.
2. As soon as the wheels are on the plate high friction braking surfaces, gradually apply the secondary brake, keeping any "hold-on" button or trigger in the disengaged position the whole time, until maximum effort is achieved.
3. Note the way in which the brake efforts increase and the maximum values achieved.

If a vehicle fails any aspect of the plate brake test, the check should be repeated to confirm the result.

#### Using a Decelerometer

If the vehicle or system is of a type which cannot be tested on a roller brake tester:

1. Set up the decelerometer in the vehicle in accordance with the equipment manufacturer's instructions.
2. Drive the vehicle on a level road at a steady speed of approximately 20mph (32kph) and progressively apply the secondary brake to maximum.
3. Note the brake efficiency recorded.

#### Brake Test Results

For details of entering brake test results, see Section 1.2.2.

# 1 Brakes

Defect	Category
(a) Braking effort: (i) inadequate at any wheel (ii) not recording at any wheel.	Major Dangerous
(b) Brakes imbalance across an axle such that: (i) the braking effort from any wheel is less than 70% of the maximum effort recorded from the other wheel on the same axle. Or in the case of testing on the road, the vehicle deviates excessively from a straight line (ii) the braking effort from any wheel is less than 50% of the maximum effort recorded from the other wheel on a steered axle.	Major Dangerous
(c) A brake on any wheel grabbing severely.	Major

## 1.3.2 Secondary Brake Efficiency

For vehicles with a single line braking system, the following minimum secondary brake efficiency requirements apply.

M2 and M3 vehicles having a service brake operating on at least 4 wheels which were first used before 1 January 1968.	20%
Vehicles first used before 1 January 1968 which do NOT have one means of control operating on at least 4 wheels and which have one brake system with two means of control or two brake systems with separate means of control.	25% from 2 <sup>nd</sup> means of control
All other vehicles.	25%

Vehicles first used before 1 January 1915 only require one efficient braking system.

Defect	Category
(a) Secondary brake efficiency: (i) below minimum requirement (ii) less than 50% of the required value met.	Major Dangerous

## 1.4 Parking brake performance and efficiency

### 1.4.1 Performance

This inspection only applies to vehicles that have not already had the parking brake system tested as the secondary brake.

**These vehicles must instead meet the secondary brake test requirements** see Section 1.3.1 and 1.3.2.

To avoid possible damage when testing transmission parking brakes, the minimum parking brake efficiency requirement must be calculated before the brake is tested and testing of the brake must cease as soon as the minimum efficiency requirement is reached.

A very small number of large vehicles, such as some American motor caravans, have a parking brake which is not suitable for a dynamic brake test. In these circumstances a gradient test must be carried out.

Three-wheeled vehicles only require a parking brake on one wheel.



# 1 Brakes

## Using a Roller Brake Tester

On each axle which has a parking brake fitted:

1. Run the rollers and gradually apply the parking brake keeping any “hold-on” button or trigger in the disengaged position the whole time.
2. Continue to apply the brake until maximum effort is achieved, or until the wheels lock and slip on the rollers.
3. Record the reading at which the maximum braking effort is achieved and whether “lock-up” occurs. Stop the rollers if they have not stopped automatically.

**Large vehicles fitted with spring brakes**, lock actuators or air assisted parking brakes may require an applied brake test in respect of parking brake efficiency. This test must only be carried out using an approved Class 5 roller brake tester with the appropriate ‘Applied Brake Test’ programme.

In these cases, fully apply the parking brake (the service brake may be used to assist in setting the parking brake) and then release any power assistance. Start each brake roller in turn and note the maximum effort recorded.

## Using a Plate Brake Tester

1. Drive the vehicle forwards at a steady speed of about 4mph up to the plate tester.
2. As soon as the wheels are on the plate high friction braking surfaces, gradually apply the parking brake, keeping any “hold-on” button or trigger in the disengaged position the whole time, until maximum effort is achieved.
3. Note the maximum values achieved.

If a vehicle fails any aspect of the plate brake test, the check should be repeated to confirm the result.

## Using a Decelerometer

If the vehicle or system is of a type which cannot be tested on a roller brake tester:

1. Set up the decelerometer in the vehicle in accordance with the equipment manufacturer’s instructions.
2. Drive the vehicle on a level road at a steady speed of approximately 20mph (32kph) and progressively apply the parking brake to maximum.
3. Note the brake efficiency recorded.

**Decelerometer brake testing** must always be carried out on suitable roads which have a minimum of traffic. A particular public road should not be used for tests so frequently that it could cause complaints from residents.

## Using a Gradient Tester

On vehicles that are not suitable for carrying out a parking brake test with the primary brake tester or decelerometer, a gradient tester can be used where one is available.

1. Reverse the vehicle onto the 16% gradient.
2. Hold the vehicle on the service brake whilst setting the parking brake.
3. Release the service brake and note if the vehicle is held on the gradient.

## Brake Test Results

For details of entering brake test results see Section 1.2.2.

Defect	Category
(a) Parking brake inoperative on one side, or in the case of testing on the road, the vehicle deviates excessively from a straight line.	Major

# 1 Brakes

## 1.4.2 Efficiency

**This inspection only applies to** vehicles that have not already had the parking brake system tested as the secondary brake.

**These vehicles must instead meet the secondary brake test requirements see Section 1.3.1 and 1.3.2.**

**For details of conducting the test,** see Section 1.4.1.

**M2 and M3 vehicles** having a service brake operating on at least 4 wheels which were first used before 1 January 1968 have no specified parking brake efficiency requirement. They must therefore have a parking brake capable of preventing at least two wheels from turning.

**Vehicles first used before 1 January 1915** only require one efficient braking system. There is no specified efficiency requirement to be met.

**All other vehicles** must achieve a minimum parking brake efficiency of 16%.

Defect	Category
(a) Parking brake efficiency:	Major Dangerous
(i) below minimum requirement	
(ii) less than 50% of the required value.	

## 1.5 Additional Braking Device (Retarder) Performance

**This inspection only applies to** vehicles that have an additional braking device, such as an electric or fluid retarder or an exhaust brake fitted.

**It is not necessary** to drive the vehicle to carry out this inspection.

Defect	Category
(a) Control for electronic retarder does not allow gradual variation in effort.	Major
(b) System obviously inoperative.	Major

## 1.6 Anti-lock braking system

**This inspection applies to** all ABS systems fitted.

**When testing ABS equipped vehicles,** when the road wheels are jacked clear of the ground they should not be allowed to rotate with the ignition on as this can cause the ABS system to indicate a fault which may require specialist equipment to rectify.

**If the ABS has been intentionally rendered inoperative,** the whole system must be removed. This does not apply to sensor rings or other ABS components which are an integral part of another component, such as a brake disc or drive shaft.

**It is not permissible to remove** or disable the ABS from a vehicle first used on or after 1 January 2010.

Defect	Category
(a) Warning device not working.	Major
(b) Warning device shows system malfunction.	Major
(c) Wheel speed sensors missing or damaged.	Major
(d) Wiring damaged.	Major
(e) Other components missing or damaged.	Major

# 1 Brakes

## 1.7 Electronic braking system (EBS)

This inspection only applies to vehicles fitted with an electronic braking system.

Defect	Category
(a) Warning device not working.	Major
(b) Warning device shows system malfunction.	Major

## 1.8 Brake fluid

The check of hydraulic brake fluid is confined to transparent reservoirs; reservoir caps should not be removed.

Defect	Category
(a) Brake fluid contaminated.	Major

## Section 2 – Contents

### 2.1 Mechanical Condition

- 2.1.1 Steering gear condition
- 2.1.2 Steering gear security
- 2.1.3 Steering linkage condition
- 2.1.4 Steering linkage operation
- 2.1.5 Power steering

### 2.2 Steering Wheel and Column or Handlebar, Forks and Yokes

- 2.2.1 Steering wheel or handlebar condition
- 2.2.2 Steering column or forks and yokes

### 2.3 Steering Play

### 2.4 Not in Use

### 2.5 Not in Use

### 2.6 Electronic Power Steering (EPS)

Draft

# 2 Steering

## 2.1 Mechanical Condition

### 2.1.1 Steering gear condition

With the vehicle over a pit or on a hoist and with the wheels resting on free moving turning plates, turn the steering from lock to lock and observe the operation of the steering gear. Vehicles with a beam axle can alternatively be checked with the wheels raised clear of the ground. If power steering is fitted, the engine must be running whilst turning the steering during these checks.

**The use of turning plates** is not mandatory for Class 5 vehicles but should be used if suitable plates are available.

Defect	Category
(a) Excessive roughness in operation of steering.	Major
(b) Sector shaft: (i) twisted or splines excessively worn (ii) twisted or splines worn to the extent that functionality is affected.	Major Dangerous
(c) Sector shaft: (i) excessively worn (ii) worn to the extent that functionality is affected.	Major Dangerous
(d) Sector shaft: (i) has excessive movement (ii) movement so excessive that functionality is affected.	Major Dangerous
(e) Steering box: (i) leaking oil (ii) leaking to the extent that oil is dripping.	Minor Major

### 2.1.2 Steering gear security

With the vehicle over a pit or on a hoist and the front road wheels on the ground, use an assistant to rock the steering wheel in both directions firmly against resistance or use wheel play detectors in rotational mode. Visually check the security of the steering gear.

**The term 'steering gear'** refers to any steering rack, box, idler, relay or intermediate drop arm pivot housing.

Guidance for assessing corrosion and use of the corrosion assessment tool is provided at Appendix 'A'.

# 2 Steering

Defect	Category
(a) Steering gear casing: (i) not properly attached (ii) retaining devices dangerously loose or relative movement to chassis/bodywork visible.	Major Dangerous
(b) Steering gear casing fixing holes in chassis: (i) elongated (ii) elongated to the extent that attachment is seriously affected.	Major Dangerous
(c) Steering gear fixing bolts: (i) missing or ineffective (ii) missing or ineffective to the extent that attachment is seriously affected.	Major Dangerous
(d) Steering gear casing: (i) fractured (ii) fractured and stability or attachment of casing affected.	Major Dangerous
(e) The strength or continuity of the load bearing structure within 30cm of any steering component mounting (a 'prescribed area'): (i) is significantly reduced or inadequately repaired (ii) is so weakened that control of the vehicle is likely to be adversely affected.	Major Dangerous

### 2.1.3 Steering linkage condition

With the vehicle over a pit or on a hoist and the front road wheels on the ground, carry out appropriate checks using an assistant to rock the steering wheel in both directions firmly against resistance or use wheel play detectors in rotational mode. Visually check the steering components for wear, fractures and security.

**If power steering is fitted**, the engine must be running.

**The presence and effectiveness** of some locking devices, such as locking fluid or 'nyloc' nuts, cannot readily be determined. Unless the tester is certain that a locking device is missing or ineffective the benefit of the doubt should be given.

**Relative movement** due to excessive wear **MUST** be distinguished from relative movement due to built-in clearance or spring loading of a joint.

# 2 Steering

Defect	Category
(a) A steering linkage component with: (i) relative movement between components which should be fixed (ii) excessive movement between components or likely to become detached.	Major Dangerous
(b) A steering ball joint: (i) with excessive wear or free play (ii) worn to the extent there is a serious risk of detachment.	Major Dangerous
(c) A steering linkage component: (i) fractured or deformed (ii) fractured or deformed to the extent that steering is affected.	Major Dangerous
(d) Steering linkage locking device missing or ineffective.	Major
(e) Track rod or drag link ends seriously misaligned.	Major
(f) A steering linkage component: (i) with an unsafe modification (ii) modified to the extent that steering is affected.	Major Dangerous
(g) Steering rack gaiter or ball joint dust cover: (i) damaged or deteriorated (ii) missing or no longer prevents the ingress of dirt etc.	Minor Major

## 2.1.4 Steering linkage operation

With the vehicle over a pit or on a hoist and with the road wheels on free moving turning plates and the engine running (if power steering), rotate steering wheel from lock to lock. Check the steering linkage is not fouling any part of the vehicle and the operation of steering lock stops if fitted.

**A missing steering lock stop** should only be failed where it is known to have been fitted as standard.

Defect	Category
(a) Steering linkage fouling any part of the vehicle.	Major
(b) Steering lock-stop missing or incorrectly adjusted.	Major

## 2.1.5 Power steering

**If power steering is inoperative** it may be necessary to verify whether the steering is adversely affected by road testing.

**Power steering fluid level** should be checked through any sight glass, the cap should not be removed.

**Power steering fluid leaks** should only be rejected where a component, joint or seal has failed.

# 2 Steering

Defect	Category
(a) Power steering fluid leaking or system malfunctioning.	Major
(b) Power steering fluid: (i) level below minimum mark (ii) reservoir empty.	Minor Major
(c) Power steering: (i) inoperative (ii) inoperative and steering adversely affected.	Major Dangerous
(d) Power steering component: (i) fractured or insecure (ii) fractured or insecure and steering adversely affected.	Major Dangerous
(e) Power steering component: (i) fouling or misaligned (ii) fouling or misaligned and steering adversely affected.	Major Dangerous
(f) Power steering component: (i) with an unsafe modification (ii) modified and steering adversely affected.	Major Dangerous
(g) Power steering pipe, hose or wiring excessively: (i) damaged or corroded (ii) damaged or corroded and steering adversely affected.	Major Dangerous

## 2.2 Steering Wheel and Column or Handle Bar, Forks and Yokes

### 2.2.1 Steering wheel or handlebar condition

**Before carrying out this inspection**, make sure that any mechanism for adjusting the steering column is fully locked. Exert only reasonable pressure on the steering wheel, particularly when the steering column is collapsible.

Push and pull the steering wheel or handlebar in line with the column or forks to check it is properly secured.



# 2 Steering

Defect	Category
(a) Relative movement between steering wheel and column: (i) indicating looseness (ii) such that there is a serious risk of detachment.	Major Dangerous
(b) Steering wheel: (i) retaining device missing (ii) likely to become detached.	Major Dangerous
(c) Steering wheel rim or spokes: (i) fractured or loose (ii) likely to become detached.	Major Dangerous
(d) Handlebar: (i) fractured or insecure (ii) fractured or insecure to the extent that steering is adversely affected or detachment likely.	Major Dangerous
(e) Handlebar: (i) excessively deformed or corroded (ii) deformed or corroded to the extent that steering is adversely affected or failure likely.	Major Dangerous
(f) Handlebar grips: (i) missing (ii) insecure to handlebar.	Major Dangerous

## 2.2.2 Steering column or forks and yokes

**Before carrying out this inspection**, make sure that any mechanism for adjusting the steering column is fully locked. Exert only reasonable pressure on the steering wheel, particularly when the steering column is collapsible.

**Some vehicles have flexible top bearings** for the steering column which may have more than average movement.

**Steering columns with universal joints** or flexible couplings may show some movement which is not due to excessive wear or deterioration.

Push and pull the steering wheel in line with column, push steering wheel/handle bar in various directions at right angles to the column/forks. Check visually for play and the condition of flexible couplings or universal joints.

# 2 Steering

Defect	Category
(a) Excessive movement of centre of steering wheel up or down.	Major
(b) Excessive radial movement between the top of the steering column and the shaft indicating an excessively worn top bearing.	Major
(c) Excessive deterioration of a flexible coupling.	Major
(d) Attachment of steering column:	
(i) defective	Major
(ii) defective to the extent that there is a serious risk of detachment.	Dangerous
(e) Unsafe modification to steering column, forks or fork yoke.	Major
(f) Forks or fork yoke:	
(i) deformed, fractured or insecure	Major
(ii) in such a condition that steering control is adversely affected or detachment likely.	Dangerous
(g) Steering head bearings have excessive wear or play.	Major

## 2.3 Steering play

With the road wheels on the ground pointing straight ahead, lightly turn the steering wheel left and right as far as possible without moving the road wheels and check the amount of free play at the rim of the steering wheel.

**If power steering is fitted**, the engine must be running.

**Steering wheel free play** should not exceed:

- a. 13mm for rack and pinion steering, or 48mm where there are several joints between the steering wheel and the rack
- b. 75mm for non-rack and pinion

These limits are for a standard 380mm diameter steering wheel. These should be adjusted up or down accordingly with larger or smaller diameter steering wheels.

**Play due to wear or maladjustment** must not be confused with apparent play due to the construction of the mechanism, such as caused by the deflection of flexible joints or spring compression in external power steering systems.

Defect	Category
(a) Free play in the steering, measured at the rim of the steering wheel is:	
(i) excessive	Major
(ii) excessive to the extent that safe steering is affected.	Dangerous

## 2.4 Not in use

## 2.5 Not in use

# 2 Steering

## 2.6 Electronic power steering (EPS)

If **power steering is optional fitment** on the vehicle but has been disconnected in such a way that there is no adverse effect on the steering, it is not considered to be a defect. It may be necessary to verify this by road testing.

**Manually switched Electronic Park Assist**, designed to be activated when parking the vehicle, is not considered to be a defect if the power assistance is inoperative provided the function of the steering is not adversely affected. It may be necessary to verify this by road testing.

**On 'fly by wire' steering systems**, check that the steered wheels are pointing straight ahead with the steering wheel in the straight ahead position.

Defect	Category
(a) EPS MIL indicating a system malfunction.	Major
(b) On 'fly by wire systems', the angle of the steering wheel and the angle of the road wheels is:	Major Dangerous
(i) inconsistent	
(ii) inconsistent to the extent that the steering is adversely affected.	
(c) Electronic power assistance not working.	Major

## Section 3 - Contents

- 3.1 Field of Vision
- 3.2 Condition of Glass
- 3.3 View to Rear
- 3.4 Windscreen Wipers
- 3.5 Windscreen Washers

Draft

# 3 Visibility

## 3.1 Field of Vision

**This inspection applies to** all vehicles with a windscreen, including those with opening windscreens.

**The driver's field of vision** through the windscreen and front side windows must be assessed from the driver's seat and rejection is only justified if the driver's view is materially affected. If it only affects the driver's view of the sky or the bonnet then it does not justify rejection.

This is a general assessment of driver's view – you are not required to speculate on the effects on tall or short drivers.

**If an item, such as a sat nav**, air freshener etc, is materially affecting restricting the driver's view, the tester may, at their discretion, remove the item prior to the inspection. The presenter should be informed of this fact.

**Additional interior mirrors and items mounted forward of the windscreen**, such as mascots and spare wheels are not part of the test.

**Taxi signs** displayed in the windscreen of Hackney Carriage vehicles to indicate when the vehicle is 'for hire' (usually by being illuminated) and 'official' stickers, such as parking and disabled permits, are only considered a defect if they seriously restrict the driver's view.

**Original vehicle design characteristics**, such as opaque edging and modifications to security type vehicles, such as additional windscreen protection or strengthening supports are to be accepted.

**A sun visor** fitted to the driver's side, which cannot be stowed in the 'off screen' position and which drops down obstructing the view of the road through the swept area of the windscreen may be considered a defect.

**Wiper blades that automatically park** in a position that obscures the view through the windscreen may be considered a defect.

**The inspection of the bonnet** only applies to vehicles with a bonnet, which when opened, would obscure the driver's view of the road.

Defect	Category
(a) An obstruction:	
(i) within the driver's field of view that materially affects his view in front or to the sides outside the swept area of windscreen	Minor
(ii) materially affecting the driver's view of the road through the swept area of the windscreen or an obligatory external mirror not visible.	Major
(b) A bonnet:	
(i) which cannot be safely secured in the closed position	Major
(ii) seriously at risk of opening inadvertently.	Dangerous
(c) A bonnet primary retaining device excessively deteriorated, ineffective or insecure.	Major

## 3.2 Condition of glass

**This inspection applies to** windscreens and the windows on either side of the driver's seat.

**Manufacturer's original design** characteristics are to be accepted.

**Where a windscreen is damaged**, it should not be rejected unless the damage is at least:

- in zone A is not contained within a 10mm diameter circle
- in the remainder of the swept area is not contained within a 40mm diameter circle.

# 3 Visibility

In either case, failure is only justified where the damage materially affects the driver's view of the road. It is not necessary to speculate on the effects on tall or short drivers.

Zone 'A' is:

- in the swept area of the windscreen.
- 290mm wide
- Centred on the steering wheel

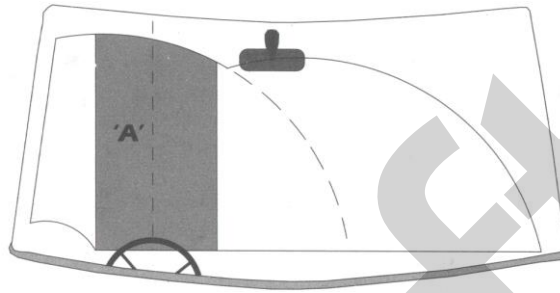

**Repaired windscreens** must be judged solely on whether the repair interferes with vision. An 'invisible' or barely detectable repair, finished flush with the surrounding glass, does not count as damage even if it exceeds the limit on damage allowed in the test.

From the driver's seat check the view of the road as well the view of obligatory external mirrors. A windscreen or window should only be rejected for tinting or discolouration if the driver's view is obviously significantly affected.

Defect	Category
(a) Windscreen or window damaged or seriously discoloured:	
(i) but not adversely affecting driver's view	Minor
(ii) and affecting the driver's view of the road or of an obligatory external mirror.	Major
(b) Windscreen or window excessively tinted:	
(i) but not adversely affecting driver's view	Minor
(ii) and visibility through swept area of windscreen or of an obligatory external mirror seriously affected.	Major
(c) Windscreen or window:	
(i) in an unacceptable condition e.g. due to excessive scratching	Major
(ii) in such a condition that visibility through swept area is seriously affected.	Dangerous

### 3.3 View to rear

**This inspection only applies to** obligatory rear view mirrors or indirect vision devices.

There are three acceptable rear view mirror/device positions:

- an exterior mirror or device that provides a view along the offside of the vehicle
- an exterior mirror or device that provides a view along the nearside of the vehicle
- an interior mirror or device which provides a view to the rear of the vehicle.

**Indirect vision devices** (cameras) may replace mirrors on some vehicles, with the view to the rear displayed on a screen in the driver's cabin. Where such devices are fitted, the inspection applies to both the camera(s) and the screen.

# 3 Visibility

The driver's view to the rear should be assessed from the driver's seat. It is not generally necessary to adjust mirrors or devices for this check.

## Obligatory Mirror or Device Fitment Positions

Vehicle Type	Date of First Use	Requirements
Passenger vehicles with less than 8 passenger seats	First used before 1 August 1978	At least one mirror/device in any of the above positions
Any passenger vehicle (excluding buses and minibuses)	First used on or after 1 August 1978	Two mirrors/devices, one of which must be in position 'a'.
Passenger vehicles with 8 or more passenger seats (excluding buses and minibuses)	Any age	
Goods vehicles	Any age	
Buses and minibuses	First used before 1 August 1983	An exterior mirror/device fitted on both the offside and the nearside ('a' and 'b').
	First used on or after 1 August 1983	

Defect	Category
(a) Obligatory mirror or device missing.	Major
(b) Obligatory mirror or device:	
(i) slightly damaged or loose	Minor
(ii) inoperative, excessively damaged or insecure.	Major
(c) Obligatory mirror or device not providing an adequate view to the rear.	Major

### 3.4 Windscreen wipers

**This inspection applies to** all vehicles, except those with an opening windscreen, or with some other means of providing the driver with an adequate view.

'Adequate view' means the view of the road, through the windscreen, to the left and right sides as well to the front.

**A windscreen wiper should only be rejected** for being 'defective' if there are clear signs of damage or wear.

Defect	Category
(a) Wiper not operating or missing.	Major
(b) Wiper blade:	
(i) defective	Minor
(ii) missing or obviously not clearing the windscreen.	Major

### 3.5 Windscreen washers

**This inspection applies to** all vehicles, except those with an opening windscreen, or with some other means of providing the driver with an adequate view.

'Adequate view' means the view of the road, through the windscreen, to the left and right sides as well to the front.

# 3 Visibility

Washers must provide sufficient fluid for the wipers to clear the windscreen effectively.

Defect	Category
(a) Windscreen washers not working or not providing sufficient fluid to clear the windscreen.	Major

Draft



# 4 Lamps, Reflectors and Electrical Equipment

## Section 4 – Contents

### 4.1 Headlamps

- 4.1.1 Presence, condition and operation
- 4.1.2 Alignment
- 4.1.3 Switching
- 4.1.4 Compliance with requirements
- 4.1.5 Levelling devices
- 4.1.6 Headlamp cleaning devices

### 4.2 Front and Rear Position Lamps, Side Marker Lamps and End Outline Marker Lamps

- 4.2.1 Presence, condition and operation
- 4.2.2 Switching
- 4.2.3 Compliance with requirements

### 4.3 Stop Lamps

- 4.3.1 Presence, condition and operation
- 4.3.2 Switching
- 4.3.3 Compliance with requirements

### 4.4 Direction Indicators and Hazard Warning Lamps

- 4.4.1 Presence, condition and operation
- 4.4.2 Switching
- 4.4.3 Compliance with requirements
- 4.4.4 Flashing frequency

### 4.5 Front and Rear Fog Lamps

- 4.5.1 Presence, condition and operation
- 4.5.2 Not in use
- 4.5.3 Switching
- 4.5.4 Compliance with requirements

### 4.6 Reversing Lamps

- 4.6.1 Condition and operation
- 4.6.2 Compliance with requirements
- 4.6.3 Switching

### 4.7 Rear Registration Plate Lamps

- 4.7.1 Condition and operation
- 4.7.2 Compliance with requirements

### 4.8 Rear reflectors

- 4.8.1 Presence, condition and operation
- 4.8.2 Compliance with requirements

# 4 Lamps, Reflectors and Electrical Equipment

---

## 4.9 'Tell-tales' Mandatory for Lighting Equipment

4.9.1 Condition and operation

4.9.2 Compliance with requirements

## 4.10 Trailer Electrical Socket

## 4.11 Electrical Wiring

## 4.12 Not in Use

## 4.13 Battery(ies)

Draft

# 4 Lamps, Reflectors and Electrical Equipment

## 4.1 Headlamps

### 4.1.1 Presence, condition and operation

The inspection applies to all obligatory headlamps fitted.

Vehicles not fitted with front or rear position lamps, or have such lamps permanently disconnected, painted over or masked, are not required to be fitted with headlamps.

Headlamps are not required on vehicles first used before 1 January 1931.

Obligatory headlamps consist of a matched pair of main beam headlamps and a matched pair of dipped-beam headlamps. These functions may be provided by a single pair of headlamps.

A “matched pair” is a pair of lamps which:

- emit light of substantially the same colour and intensity, and
- are the same size and of such a shape that they are symmetrical to one another.

Buses first used before 1 October 1969 require only one headlamp. Where two are fitted, neither the main or dipped beams are required to form matched pair.

A ‘light source’ means any bulb, LED or other means of emitting light.

Repairs to lamps must be assessed considering security, colour, light output, durability and beam aim.

Tricycle and quadricycle dipped and main beam headlamps requirements are as follows:

- If one, it must be mounted centrally, or if adjacent to another lamp, e.g. one dipped beam lamp and one main beam lamp, they must be mounted symmetrically about the centre.
- If two, they must be symmetrically mounted.
- If the maximum vehicle width exceeds 1300mm, two dipped and main beam headlamps are required (1700mm for motorcycle derived tricycles)

Tricycles and quadricycles classed as mopeds do not require a main beam headlamp.

Defect	Category
(a) A headlamp:	
(i) with up to ½ light sources not functioning in the case of LED	Minor
(ii) missing, inoperative or more than ½ not functioning in the case of LED.	Major
(b) Headlamp reflector or lens:	
(i) slightly defective	Minor
(ii) seriously defective or missing	Major
(c) Lamp not securely attached.	Major

### 4.1.2 Headlamp alignment

This inspection applies to all obligatory and any additional dipped beam headlamps.

The type of headlamp will determine whether the aim must be checked on dipped or main beam (see diagrams 1, 2 and 3).

A flat top or other alternative headlamp dipped beam pattern (not being one of the examples) is acceptable providing all of the beam upper edge, including any “peak” is contained within the appropriate tolerance band.

It is acceptable for masks or converter kits to be fitted to right hand dip headlamps to temporarily alter the lamp for use in the UK by removing the beam ‘kick-up’ to the right.

# 4 Lamps, Reflectors and Electrical Equipment

Where driver's beam aim controls are fitted, the beam aim should be tested without altering the control setting. If this would result in failure for beam aim being too low, the beam aim should be re-checked with the control set at its 'highest' position.

On vehicles with hydro-pneumatic suspension systems, it is necessary to have the engine running when checking headlamp aim.

## Procedure

Position the vehicle on the designated headlamp aim standing area and align the headlamp aim testing equipment to the vehicle in accordance with the manufacturer's instructions.

Determine the appropriate headlamp beam image and its aim (see diagrams 1, 2 and 3).

When testing headlamps with complex lens systems i.e. those that have more than one lamp behind a single lens, it is essential that the headlamp aim test equipment is aligned exactly on the centre of the dipped beam pocket.

Repairs must not be carried out during an MOT test; however, minor adjustments to the headlamp aim are acceptable.

## European Type (Checked on dipped beam)

Characteristics:

- (a) an asymmetric dipped beam pattern with:
  - a distinctive horizontal cut-off on the right, and
  - a visible wedge of light above the horizontal (the 'Kick up') towards the left
- (b) a lens may carry a European approval mark

Alignment Requirements:

- If the beam image contains a "kick up", this must be visible on the screen
- For headlamps with centres **not more than** 850mm from the ground the beam image horizontal cut-off must not be above the horizontal 0.5% line or below the 2.75% line
- For headlamps with centres **more than** 850 mm from the ground, the beam image horizontal cut-off must not be above the horizontal 1.25% or below the 2.75% line
- White light must not show in the zone formed by the 0% vertical and 0.5% horizontal lines

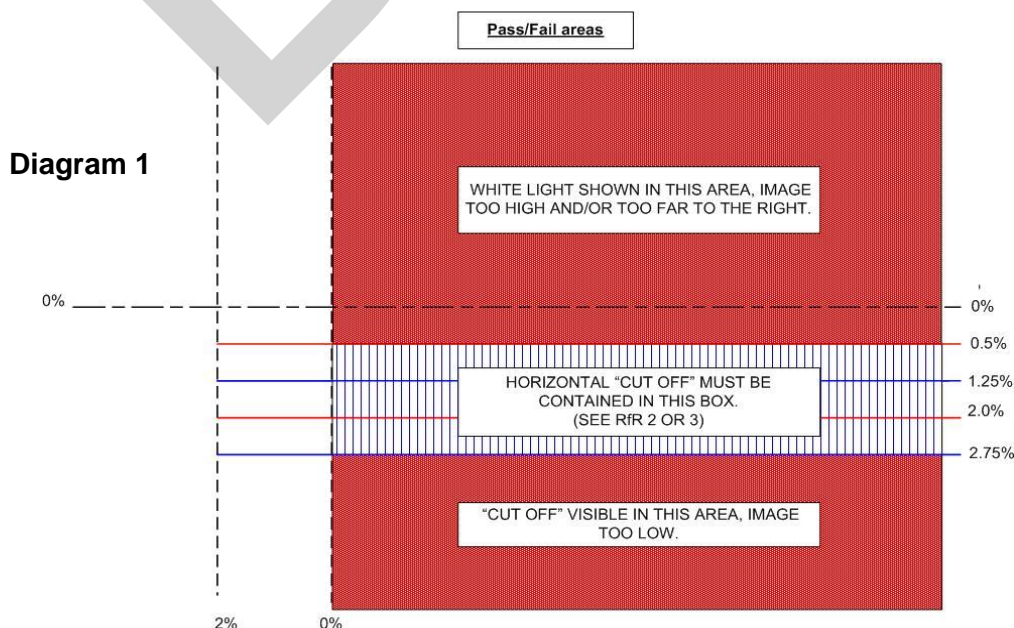

# 4 Lamps, Reflectors and Electrical Equipment

## British American Headlamp (Checked on Main Beam)

Characteristics:

- A symmetrical main beam pattern with a central area of maximum intensity ('hot spot')
- This type of lamp generally has a circular lens which may be marked with a figure '1' followed by an arrow indicating the direction of dip.

Alignment Requirements:

- The "hot spot" centre must not be above the horizontal 0% line
- For headlamps with centres **not more than** 850mm from the ground the "hot spot" centre must not be below the horizontal 2% line
- For headlamps with centres **more than** 850 mm from the ground the "hot spot" centre must not be below the horizontal 2.75% line
- When dipped the brightest part of the image must move downwards
- The 'hot spot' centre must not be to the right of the vertical 0% line or to the left of the vertical 2% line

Diagram 2 - Main beam image

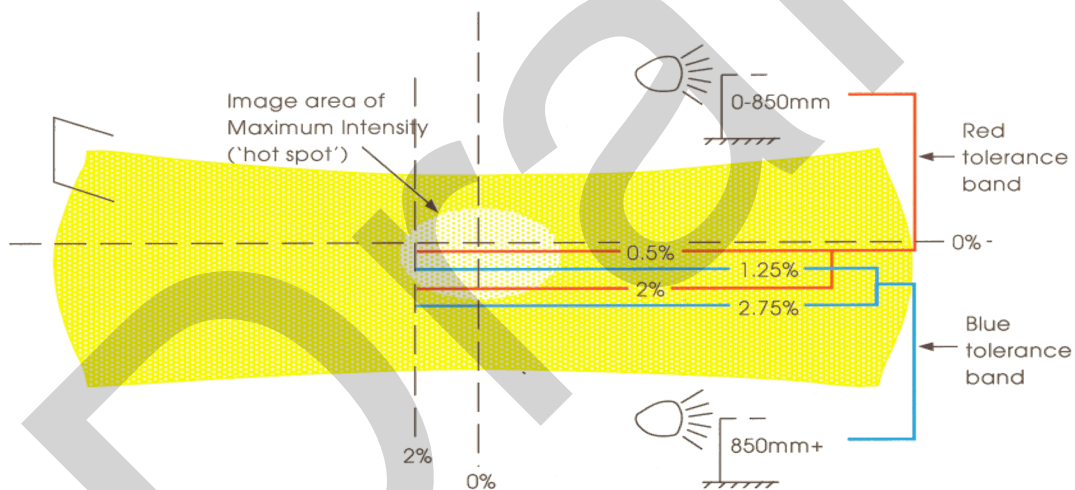

Check the position of the centre of the area of maximum intensity ('hot spot')

## British American Headlamp (Checked on Dipped Beam)

Characteristics:

- an asymmetric dipped beam pattern which when correctly aimed has a flat topped area of high intensity extending above and parallel with the horizontal zero line on the nearside
- a circular lens marked with the figure 2 which may also have an arrow showing the direction of dip.

Alignment Requirements:

- The upper edge of the "hot spot" must not be above the horizontal 0% line
- The upper edge of the 'hot spot' must not be below the horizontal 2.75% line
- The right hand edge of the 'hot spot' must not be to the right of the vertical 0% line or to the left of the vertical 2% line

# 4 Lamps, Reflectors and Electrical Equipment

Diagram 3 - Dipped beam image

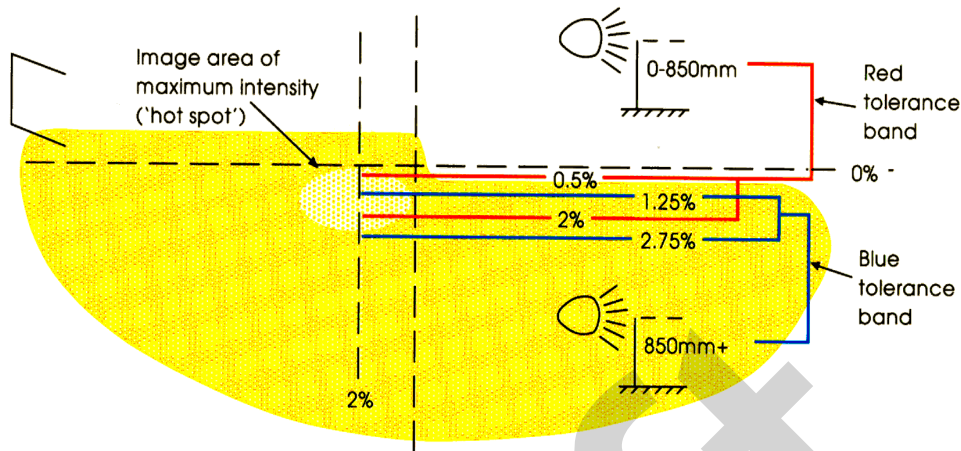

Check the position of the upper and right hand edges of the 'hot spot'.

Defect	Category
(a) The aim of a headlamp is not within limits laid down in the requirements.	Major
(b) Headlamp aim unable to be tested.	Major

## 4.1.3 Switching

**The headlamps should immediately illuminate** all dipped or main beam headlamps when switched on (depending on the position of the dip-switch).

**Headlamps must also operate immediately** when selected on dipped or on main beam.

**Operation of the dip switch** must:

- extinguish all main beam headlamps, and leave on at least one pair of dipped-beam headlamps, or
- deflect the main beams to make them dipped beams.

**Dipped beam headlamps** may remain on or switch off when main beam is selected.

**Headlamps are not required** on vehicles first used before 1 January 1931. However, if optional headlamps are fitted:

- where one is fitted it must dip
- where two are fitted, either both must dip or one must dip and the other switch off.

Defect	Category
(a) Headlamp 'on' switch does not operate in accordance with the requirements.	Minor
(b) Headlamp 'dip' switch does not operate in accordance with the requirements.	Major

## 4.1.4 Compliance with requirements

**This inspection applies to** all obligatory headlamps fitted.

**Headlamps are not required** on vehicles first used before 1 January 1931.

**Obligatory headlamps** consist of a matched pair of main beam headlamps and a matched pair of dipped-beam headlamps. These functions may be provided by a single pair of headlamps.

# 4 Lamps, Reflectors and Electrical Equipment

**Tricycle and quadricycle** dipped and main beam headlamps requirements are as follows:

- If one, it must be mounted centrally, or if adjacent to another lamp, e.g. one dipped beam lamp and one main beam lamp, they must be mounted symmetrically about the centre.
- If two, they must be symmetrically mounted.
- If the maximum vehicle width exceeds 1300mm, two dipped and main beam headlamps are required (1700mm for motorcycle derived tricycles)

Tricycles and quadricycles classed as mopeds do not require a main beam headlamp.

**A “matched pair”** is a pair of lamps which:

- Both emit light of substantially the same colour and intensity, and
- Are both the same size and of such a shape that they are symmetrical to one another.

**In a four-headlamp system** the outer headlamps need not emit the same colour light as the inner pair.

**Headlamps must be either white or yellow.** Some headlamps have a blue tinge to the light. This is acceptable provided the light is predominantly white.

**The precise position of lamps** is not part of the inspection, but check visually that they are at about the same height and the same distance from each side of the vehicle.

**If a lamp is in such a condition** that the intensity is significantly reduced it should be rejected.

**Buses first used before 1 October 1969** are only required to be fitted with one headlamp. Where two are fitted, neither the main or dipped beams are required to form matched pair.

**Some vehicles may be fitted with High Intensity Discharge (HID)** headlamps. It is not permitted to convert existing halogen headlamp units for use with HID bulbs. If it is clear that such a conversion has been carried out, rather than replacing the entire unit with one designed and approved for use with HID bulbs, the headlamp should be rejected.

**A ‘light source’** means any bulb, LED or other means of emitting light.

**Repairs to lamps** must be assessed considering security, colour, light output and durability.

Defect	Category
(a) Headlamp emitted colour, position or intensity not in accordance with the requirements.	Major
(b) Product on the lens or light source which obviously reduces light intensity or changes emitted colour to other than white or yellow.	Major
(c) Light source and lamp not compatible.	Major

## 4.1.5 Levelling devices

**Where a manual headlamp levelling device** (driver control) is fitted it must work. Before operating the control, check the setting it is on and return it to the same place.

**Vehicles equipped with High Intensity Discharge (HID)** or LED dipped beam headlamps may be fitted with a suspension or headlamp self-levelling system. Where such systems are fitted, they must work; however, it is accepted that it may not be possible to readily determine the functioning of self-levelling systems. In such cases, the benefit of the doubt must be given.

HID lamps may have ‘DCR’ marked on the headlamp lens, otherwise they can be identified by:

- taking a few seconds to reach full intensity
- having a bluish tinge to the light
- having an igniter module/inverter behind the headlamp

# 4 Lamps, Reflectors and Electrical Equipment

HID headlamps use high voltage and extra care should be taken when inspecting these items.

Defect	Category
(a) Headlamp levelling device inoperative.	Major
(b) Manual levelling device cannot be operated from the driver's seat.	Major

## 4.1.6 Cleaning devices

**This inspection only applies to** vehicles first used on or after 1 September 2009 equipped with headlamp washers.

**HID lamps** may be identified by:

- taking a few seconds to reach full intensity
- having a bluish tinge to the light
- having an igniter module/inverter behind the headlamp
- having 'DCR' marked on the headlamp lens or body.

HID headlamps use high voltage and extra care should be taken when inspecting these items.

Defect	Category
(a) Headlamp cleaning device:	
(i) inoperative	Minor
(ii) inoperative in the case of LED or gas discharge systems (HID)	Major

## 4.2 Front and rear position lamps, end outline marker lamps and daytime running lamps

### 4.2.1 Presence, condition and operation

**This inspection applies to** obligatory position lamps and end outline marker lamps.

**It also applies to daytime running lamps (DRLs)** fitted to M1 vehicles first used on or after 20 May 2018.

**It is permitted for vehicles** to not be fitted with position lamps, or to have such lamps permanently disconnected, painted over or masked. If this situation occurs, an advisory notice should be issued recording this fact. Vehicles that meet these criteria do not require end-outline marker lamps.

### All Lamps

**Repairs to lamps** must be assessed, considering security, colour, light output and durability.

### Front and Rear Position Lamps

**Two front and two rear** position lamps must be fitted other than on a tricycle or quadricycle.

**By design, the front position lamp** function may be carried out by the Daytime Running Lamps (DRLs) or the headlamps. Where the front position lamp function is carried out by the DRLs, the DRLs may dim when the rear position lamps are switched on and may extinguish when the headlamps are illuminated.

The front position lamps may also extinguish when the front fog lamps are illuminated.

**The front and rear position lamps** must illuminate simultaneously with the registration plate lamps and end-outline marker lamps where they are fitted.

**Tricycles and quadricycles** may have one or two front and rear position lamps. However, if the maximum vehicle width exceeds 1300mm, two front and two rear position lamps are required.



# 4 Lamps, Reflectors and Electrical Equipment

Where only one lamp is fitted, it must be mounted centrally and if two they must be symmetrically mounted. However, if a single front position lamp is mounted adjacent to another front lamp (e.g. a headlamp) they must be mounted symmetrically about the centre.

Only one rear position lamp is required on a bus first used before 1 April 1955 which must be on the centre-line or to the offside.

## End-outline Marker Lamps

**The inspection of end-outline marker lamps** applies to vehicles first used on or after 1 April 1991, that exceed 2.1 metres (2100mm) in width, other than Class 3 vehicles. The front and rear end outline marker lamps on each side may be combined in one lamp.

## Daytime Running Lamps

**The inspection of daytime running lamps (DRLs)** applies only to those fitted as original equipment to vehicles first used on or after 01 March 2018.

Defect	Category
(a) A lamp missing or inoperative.	Major
(b) Defective lens.	Major
(c) Lamp:	
(i) not securely attached	Minor
(ii) likely to become detached.	Major

### 4.2.2 Switching

**The position lamps** must illuminate with a single operation of the switch, which must be able to be operated from the driver's seat. End outline marker lamps (where required) must illuminate simultaneously with the position lamps.

**The function of a lamp** must not be adversely affected by the operation of any other lamp. However, the function of the front position lamps may be carried out by the daytime running lamps (DRLs), front fog lamps or the headlamps.

Where the front position lamp function is carried out by the DRLs, they may dim when the rear position lamps are switched on and may extinguish when the headlamps are illuminated.

The front position lamps may switch off when the headlamps or front fog lamps are illuminated.

**Some vehicles have position lamps** combined with the direction indicators. In these cases the position lamp will extinguish whilst the relevant direction indicator is flashing.

**The front and rear position lamps** must illuminate simultaneously with the end-outline marker lamps where they are fitted.

**The inspection of daytime running lamps (DRLs)** applies only to those fitted as original equipment to vehicles first used on or after 01 March 2018.

**DRLs must switch on and off** with the ignition or its equivalent, however, DRLs may not operate when the engine is not running, or when the parking brake is applied, or when the park position is selected on automatic transmissions. They can also be manually switched off, in which case they may not illuminate until the vehicle speed exceeds 10km/h or the vehicle has travelled 100m.

Defect	Category
(a) Switch does not operate in accordance with the requirements or the rear position lamps can be switched off when the headlamps are on.	Major
(b) Function of the switch impaired.	Major

# 4 Lamps, Reflectors and Electrical Equipment

## 4.2.3 Compliance with requirements

**This inspection applies to** obligatory position lamps and end outline marker lamps.

It also applies to all daytime running lamps fitted on vehicles first used on or after 01 March 2018.

### All Lamps

**The precise position of lamps** is not part of the inspection, but check visually that they are at about the same height and the same distance from each side of the vehicle.

**A 'light source'** means any bulb, LED or other means of emitting light.

**Repairs to lamps** must be assessed, considering security, colour, light output and durability.

### Position Lamps

**Rear position lamps** must show a steady red light and front position lamps must show a steady white light (or yellow if incorporated in a yellow headlamp). Some front position lamps have a blue tinge to the light, which is acceptable provided the light is predominantly white.

**Some vehicles have position lamps** combined with the direction indicators. In these cases the position lamp will extinguish whilst the relevant direction indicator is flashing.

### End-outline Marker Lamps

**The inspection of end-outline marker lamps** applies to vehicles first used on or after 1 April 1991, that exceed 2.1 metres (2100mm) in width other than Class 3 vehicles.

**There must be two white lamps**, visible from the front, positioned at windscreen upper edge level or higher and two red lamps visible from the rear, positioned as high as is practicable. The front and rear end outline marker lamps on each side may be combined in one lamp.

### Daytime Running Lamps

**The inspection of daytime running lamps (DRL)** applies only to those fitted as original equipment to vehicles first used on or after 01 March 2018. Only two DRLs can be fitted and they must be white in colour.

**DRLs may not operate** when the engine is not running, when the parking brake is applied, or when the park position is selected on automatic transmissions. They can also be manually switched off, in which case they may not illuminate until the vehicle speed exceeds 10km/h or the vehicle has travelled 100m.

Defect	Category
(a) Lamp:	
(i) emitted colour, position or intensity not in accordance with the requirements	Minor
(ii) showing red light to the front, white light to the rear or has heavily reduced light intensity.	Major
(b) A lamp with a product on the lens or light source:	
(i) which obviously reduces light intensity or changes emitted colour	Minor
(ii) which shows red light to the front, white light to the rear or has heavily reduced light intensity.	Major

## 4.3 Stop lamps

### 4.3.1 Presence, condition and operation

**This inspection applies to** all stop lamps fitted.

**Stop lamps are not required** to be fitted to vehicles not fitted with front and rear position lamps, or have such lamps permanently disconnected, painted over or masked.

# 4 Lamps, Reflectors and Electrical Equipment

Stop lamps are not required on vehicles first used before 1 January 1936.

**Vehicles first used on or after 1 January 1971** must have two stop lamps, one on each side. Vehicles first used before this date may be fitted with only one stop lamp, which can be mounted centrally or towards the offside.

**Additional stop lamps**, over and above the obligatory requirements, must be tested. However, if there is doubt as to whether they are connected, the benefit of this doubt should be given.

**A 'light source'** means any bulb, LED or other means of emitting light.

**Repairs to lamps** must be assessed, considering security, colour, light output and durability.

**Tricycles and quadricycles** may have one or two stop lamps. However, if the maximum vehicle width exceeds 1300mm, two stop lamps are required. Where only one lamp is fitted, it must be mounted centrally and if two they must be symmetrically mounted.

Defect	Category
(a) Stop lamp(s):	
(i) with a multiple light source up to 1/2 not functioning	Minor
(ii) missing, inoperative or in the case of a multiple light source more than 1/2 not functioning	Major
(iii) all missing or inoperative.	Dangerous
(b) A lens defective:	
(i) which has no effect on emitted light	Minor
(ii) such that the emitted light is adversely affected.	Major
(c) A stop lamp:	
(i) not securely attached	Minor
(ii) likely to become detached.	Major

## 4.3.2 Switching

**All stop lamps should illuminate immediately** the brake is applied and extinguish immediately the brake is released.

**Vehicles first used on or after 1 January 1971** must have two stop lamps, one on each side. Vehicles first used before this date may be fitted with only one stop lamp, which can be mounted centrally or towards the offside.

**Additional stop lamps**, over and above the obligatory requirements, must be tested. However, if there is doubt as to whether they are connected, the benefit of this doubt should be given.

**Vehicles first used before 1 September 1965** may have a stop lamp incorporated with a direction indicator lamp.

**Tricycles and quadricycles** may have one or two stop lamps. However, if the maximum vehicle width exceeds 1300mm, two stop lamps are required. Where only one lamp is fitted, it must be mounted centrally and if two they must be symmetrically mounted. If two service brake controls are fitted, both must operate the stop lamp(s).

# 4 Lamps, Reflectors and Electrical Equipment

Defect	Category
(a) Stop lamp(s):	
(i) switch does not operate in accordance with the requirements	Minor
(ii) switch with a delay in operation	Major
(iii) remain on when the brakes are released.	Dangerous

### 4.3.3 Compliance with requirements

**This inspection applies to** all stop lamps fitted.

**Stop lamps are not required** to be fitted to vehicles not fitted with front and rear position lamps, or have such lamps permanently disconnected, painted over or masked.

**Vehicles first used on or after 1 January 1971** must have two stop lamps, one on each side. Vehicles first used before this date may be fitted with only one stop lamp, which can be mounted centrally or towards the offside.

**Additional stop lamps**, over and above the obligatory requirements, must be tested. However, if there is doubt as to whether they are connected, the benefit of this doubt should be given.

**Repairs to lamps** must be assessed, considering security, colour, light output and durability.

**Tricycles and quadricycles** may have one or two stop lamps. However, if the maximum vehicle width exceeds 1300mm, two stop lamps are required. Where only one lamp is fitted, it must be mounted centrally and if two they must be symmetrically mounted.

Defect	Category
(a) A stop lamp:	
(i) emitted colour, position or intensity not in accordance with the requirements	Minor
(ii) showing white light to the rear or significantly reduced light intensity.	Major

## 4.4 Direction Indicators and Hazard Warning Lamps

### 4.4.1 Presence, condition and operation

**This inspection applies to** all direction indicators and hazard warning lamps fitted.

**Direction indicators and hazard warning lamps are not required** to be fitted to vehicles not fitted with front and rear position lamps or have such lamps permanently disconnected, painted over or masked.

Direction indicators are not required on vehicles first used before 1 January 1936.

**Vehicles first used on or after 1 April 1986** must be fitted with one side repeater indicator on each side. Instead of a separate lamp, the side repeater might be part of the front direction indicator if it includes a wraparound lens marked either with an 'E' mark in a circle or an 'e' mark in a rectangle above which is a number 5.

However, some vehicles are fitted with a wraparound lens with no European approval markings. These can be checked by standing approximately 1m to the side of the rear bumper with the indicator on. If amber light can be seen coming through the front lens (not a reflection) this is acceptable.

**Semaphore arms**, where fitted, may flash but are not required to do so.

**Hazard warning devices** are not required on vehicles first used before 1 April 1986.

**A 'light source'** means any bulb, LED or other means of emitting light.

# 4 Lamps, Reflectors and Electrical Equipment

**Repairs to lamps** must be assessed, considering security, colour, light output and durability.

**Tricycles and quadricycles** classed as mopeds do not require hazard warning lamps. Direction indicators are only required on 'bodied' mopeds.

Defect	Category
(a) A direction indicator:	
(i) lamp with a multiple light source up to 1/2 not functioning	Minor
(ii) lamp missing, inoperative or in the case of a multiple light source more than 1/2 not functioning	Major
(b) A lens defective:	
(i) which has no effect on emitted light	Minor
(ii) such that the emitted light is adversely affected.	Major
(c) A lamp:	
(i) not securely attached	Minor
(ii) likely to become detached.	Major

## 4.4.2 Switching

**Hazard warning lamps** must operate by the use of only one switch and with the engine or ignition switch in both the on and off positions.

**Tricycle and quadricycle** switching requires the hazard warning lamps to work both with the engine running and switched off. This may be by use of an engine kill switch or by turning the ignition off.

Defect	Category
(a) Indicator or hazard warning switch:	
(i) does not operate in accordance with the requirements	Minor
(ii) inoperative.	Major

## 4.4.3 Compliance with requirements

**Direction indicators must be amber**, although vehicles first used before 1 September 1965 may have direction indicators incorporated with stop lamps, or combined with front or rear position lamps in which case front indicators may be white and rear indicators red.

**Some vehicles have direction indicators combined** with the position lamps. In these cases the position lamp will extinguish whilst the relevant direction indicator is flashing. The lamp must flash amber only and not amber/white or amber/red.

**A semaphore arm** must illuminate when in operation. It may flash, but is not required to do so.

**The precise position of lamps** is not part of the inspection, but check visually that they are at about the same height and the same distance from each side of the vehicle.

**Repairs to lamps** must be assessed, considering security, colour, light output and durability.

Defect	Category
(a) Lamp emitted colour, position or intensity not in accordance with the requirements.	Major

# 4 Lamps, Reflectors and Electrical Equipment

## 4.4.4 Flashing frequency

**Indicators must flash** at between 60 and 120 times per minute. Semaphore type direction indicators are not required to flash.

Defect	Category
(a) Rate of flashing not between 60 and 120 times per minute.	Minor

## 4.5 Front and rear fog lamps

### 4.5.1 Presence, condition and operation

**This inspection only applies to:**

- front fog lamps fitted to vehicles first used on or after 1 March 2018
- the one rear fog lamp which is required to be fitted to the centre or offside of vehicles first used on or after 1 April 1980.

**A rear fog lamp is not required** on tricycles or quadricycles or on vehicles not fitted with front and rear position lamps or have such lamps permanently disconnected, painted over or masked.

**Front and rear fog lamps** are permitted to operate independently of any other lamps or ignition systems.

**Front fog lamps must show a steady white light** to the front and rear fog lamps must show a steady red light to the rear.

**A 'light source'** means any bulb, LED or other means of emitting light.

**Repairs to lamps** must be assessed, considering security, colour, light output and durability.

Defect	Category
(a)	
(i) A front or rear fog lamp with a multiple light source up to 1/2 not functioning	Minor
(ii) An obligatory rear fog lamp missing, or a front or rear fog lamp inoperative or in the case of a multiple light source more than 1/2 not functioning.	Major
(b) A lens defective:	
(i) which has no effect on emitted light	Minor
(ii) such that emitted light is adversely affected.	Major
(c) A front or rear fog lamp:	
(i) not securely attached	Minor
(ii) likely to become detached.	Major

### 4.5.2 Not in use

### 4.5.3 Switching

**Front and rear fog lamp switches** may be combined or independent switches. The switch(es) must be secure, able to be operated from the normal driving position and operate the lamp(s) as intended.

**Front and rear fog lamps** are permitted to operate independently of any other lamps or ignition systems.

# 4 Lamps, Reflectors and Electrical Equipment

The function of a fog lamp must not be adversely affected by the operation of any other lamp.

Rear fog lamps may be incorporated with the rear position lamps.

Defect	Category
(a) Front or rear fog lamp switch:	
(i) not operating in accordance with the requirements	Minor
(ii) inoperative.	Major

## 4.5.4 Compliance with requirements

This inspection applies to:

- all front fog lamps fitted to vehicles first used on or after 1 March 2018
- the one rear fog lamp which is required to be fitted to the centre or offside of vehicles first used on or after 1 April 1980.

A rear fog lamp is not required on tricycles, quadricycles or vehicles not fitted with front and rear position lamps or have such lamps permanently disconnected, painted over or masked.

Front fog lamps must show a steady white light to the front and rear fog lamps must show a steady red light to the rear.

Repairs to lamps must be assessed, considering security, colour, light output and durability.

Defect	Category
(a) Front or rear fog lamp emitted colour, position or intensity not in accordance with the requirements.	Major

## 4.6 Reversing lamps

### 4.6.1 Condition and operation

This inspection applies to all reversing lamps fitted to vehicles first used from 1 September 2009.

Reversing lamps must show a white light to the rear. On some vehicles it may be necessary to have the engine running before the reversing lamps will work.

One or two reversing lamps may be fitted, but they must all work.

Buses over 6m in length may have four reversing lamps which may be:

- all showing white light to the rear
- two showing white light to the rear and one on each side.

Defect	Category
(a) A reversing lamp inoperative.	Minor
(b) A reversing lamp lens defective.	Minor
(c) A reversing lamp:	
(i) not securely attached	Minor
(ii) likely to become detached.	Major

### 4.6.2 Compliance with requirements

This inspection applies to all reversing lamps fitted to vehicles first used from 1 September 2009.

# 4 Lamps, Reflectors and Electrical Equipment

**Reversing lamps must show a white light** to the rear. On some vehicles it may be necessary to have the engine running before the reversing lamps will work.

**One or two reversing lamps** may be fitted, but they must all work.

**Buses over 6m in length** may have four reversing lamps which may be:

- all showing white light to the rear
- two showing white light to the rear and one on each side.

Defect	Category
(a) Reversing lamp emitted colour, position or intensity not in accordance with the requirements.	Major

## 4.6.3 Switching

**This inspection applies to** all reversing lamps fitted to vehicles first used from 1 September 2009.

**Reversing lamps must operate automatically** when reverse gear is selected. On some vehicles it may be necessary to have the engine running before the reversing lamps will work.

Defect	Category
(a) Reversing lamp switch not operating in accordance with the requirements.	Major

## 4.7 Rear registration plate lamps

### 4.7.1 Presence, condition and operation

**This inspection applies to** all vehicles fitted with front and rear position lamps.

**Registration plate lamps are required** to illuminate the rear registration plate. Some vehicles may have these lamps fitted behind the number plate.

**A 'light source'** means any bulb, LED or other means of emitting light.

**Tricycles and quadricycles** classed as mopeds, do not require a rear registration plate lamp.

Defect	Category
(a) A rear registration plate lamp throwing direct white light to the rear.	Minor
(b) A rear registration plate lamp or light source missing or inoperative:	
(i) in the case of multiple lamps or light sources	Minor
(ii) in the case of a single lamp or all lamps.	Major
(c) A registration plate lamp:	
(i) not securely attached	Minor
(ii) likely to become detached.	Major

### 4.7.2 Compliance with requirements

**This inspection applies to** all vehicles fitted with front and rear position lamps.

**Registration plate lamps must operate** simultaneously with the position lamps.

**Tricycles and quadricycles** classed as mopeds, do not require a rear registration plate lamp.



# 4 Lamps, Reflectors and Electrical Equipment

Defect	Category
(a) Rear registration plate lamp does not illuminate simultaneously with the position lamps.	Major

## 4.8 Rear reflectors

### 4.8.1 Condition

**This inspection applies to** the two obligatory rear reflectors that are required to be fitted.

**Rear reflectors are not required** on vehicles not fitted with front and rear position lamps or have such lamps permanently disconnected, painted over or masked.

**Reflective tape is not acceptable** as a substitute for a rear reflector.

Defect	Category
(a) Reflector defective or damaged: <ul style="list-style-type: none"> <li>(i) by up to 50% of the reflecting surface</li> <li>(ii) by more than 50% of the reflecting surface.</li> </ul>	Minor Major
(b) Reflector: <ul style="list-style-type: none"> <li>(i) not securely attached</li> <li>(ii) likely to become detached.</li> </ul>	Minor Major

### 4.8.2 Compliance with requirements

**This inspection applies to** the two obligatory rear reflectors that are required to be fitted.

**Rear reflectors are not required** on vehicles not fitted with front and rear position lamps or have such lamps permanently disconnected, painted over or masked.

**Reflectors must be symmetrically mounted** although the precise position of obligatory rear reflectors is not part of the inspection. Check visually that they are at about the same height and the same distance from each side of the vehicle.

**Tricycles and quadricycles** exceeding 1000mm maximum width require two rear reflectors which must be mounted symmetrically. Otherwise, only one centrally mounted rear reflector is required.

Defect	Category
(a) Reflector: <ul style="list-style-type: none"> <li>(i) colour or position not in accordance with the requirements</li> <li>(ii) missing or reflecting white to the rear.</li> </ul>	Minor Major

## 4.9 Tell-tales mandatory for lighting equipment

### 4.9.1 Condition and operation

**This inspection only applies to** the following lighting 'tell-tales':

- Headlamp main-beam
- Direction Indicators
- Hazard warning lamps
- Rear fog lamps.

# 4 Lamps, Reflectors and Electrical Equipment

A main-beam 'tell-tale' is only required on vehicles first used on or after 1 April 1986. The inspection of the main-beam tell-tale does not apply to Class 3 vehicles.

A hazard warning 'tell-tale' must be a flashing light.

A direction indicator 'tell-tale' can be audible or visual.

A rear fog 'tell-tale' is only required where a rear fog lamp is obligatory.

Defect	Category
(a) A mandatory tell-tale:	
(i) for direction indicators or hazard warning missing or inoperative	Minor
(ii) for main beam headlamp or rear fog lamp missing or inoperative.	Major

## 4.9.2 Compliance with requirements

This inspection only applies to the 'tell-tale' for hazard warning lamps, which must be a flashing light.

Defect	Category
(a) A hazard warning lamp tell-tale is not a flashing light.	Minor

## 4.10 Trailer electrical socket

This inspection only applies to vehicles fitted with a towing coupling.

If a tow ball or pin is not present at the time of test, because it is detachable, has been unbolted or otherwise removed, but the attachment brackets are still in place, any trailer electrical socket should still be assessed. This does not apply if the attachment brackets have been deliberately rendered unfit for further use.

Some trailer electrical sockets are 'hidden' behind an access panel in the bumper or bodywork. Unless requiring the use of tools or specialist equipment, these panels must be removed to facilitate the inspection of the tow bar socket.

A trailer electrical socket with a defective or missing cover flap that incorporates a lug and spring to hold the plug in place is not considered to be a defect.

On vehicles fitted with a trailer 13 pin Euro-socket, use an approved device to check that the socket is wired to correctly operate the trailer:

- Position lamps
- Stop lamps
- Direction indicators
- Rear fog lamp.

# 4 Lamps, Reflectors and Electrical Equipment

Defect	Category
(a) A trailer electrical socket: (i) insecure (ii) likely to become detached.	Minor Major
(b) Trailer electrical socket wiring: (i) insulation damaged or deteriorated (ii) insulation damaged or deteriorated and likely to cause a short-circuit.	Minor Major
(c) A 13-pin trailer socket: (i) not functioning correctly (ii) not functioning at all.	Major Dangerous

## 4.11 Electrical wiring

**This inspection applies to** all visible electrical wiring. It does not apply to Class 3 vehicles.

Defect	Category
(a) Electrical wiring: (i) insecure or inadequately secured (ii) insecure and in contact with sharp edges or connectors likely to become disconnected (iii) likely to touch hot or rotating parts, drag on the ground or the connectors for braking or steering disconnected.	Minor Major Dangerous
(b) Electrical wiring: (i) slightly deteriorated (ii) heavily deteriorated (iii) for braking or steering components extremely deteriorated.	Minor Major Dangerous
(c) Electrical wiring insulation: (i) damaged or deteriorated (ii) so damaged or deteriorated it is likely to cause a short-circuit (iii) in such a condition there is an imminent risk of fire or formation of sparks.	Minor Major Dangerous

## 4.12 Not in use

## 4.13 Battery(ies)

**This inspection applies to** all vehicles, other than Class 3, including electric and hybrid vehicles.

# 4 Lamps, Reflectors and Electrical Equipment

Defect	Category
(a) A battery insecure:	
(i) but not likely to fall from carrier	Minor
(ii) and likely to fall from carrier or cause a short circuit.	Major
(b) A battery leaking.	Major

Draft

# 5 Axles, Wheels, Tyres and Suspension

---

## Section 5 – Contents

### 5.1 Axles

- 5.1.1 Axles
- 5.1.2 Stub axles
- 5.1.3 Wheel bearings

### 5.2 Wheels and Tyres

- 5.2.1 Road wheel and hub
- 5.2.2 Road wheel condition
- 5.2.3 Tyres

### 5.3 Suspension

- 5.3.1 Springs
- 5.3.2 Shock absorbers
- 5.3.3 Suspension arms, rods, struts, sub-frames, anti-roll bars etc.
- 5.3.4 Suspension joints, pins and bushes
- 5.3.5 Gas and fluid suspension
- 5.3.6 Complete suspension system

# 5 Axles, Wheels, Tyres and Suspension

## 5.1 Axles

### 5.1.1 Axles

For beam axles, the use of wheel play detectors is recommended for checking axle security.

Defect	Category
(a) An axle fractured.	Dangerous
(b) An axle:	
(i) insecure or with loose fixing bolts	Major
(ii) insecure such that stability is impaired or functionality affected.	Dangerous
(c) An axle:	
(i) with an unsafe modification	Major
(ii) modified so that vehicle stability is impaired or axle functionality affected.	Dangerous

### 5.1.2 Stub axles

Jack up the front of the vehicle so that the front wheels are clear of the ground, observing relative vertical movement between components. Then use a suitable bar under each wheel in turn and lever upwards, looking for play in components.

Then check for play in components using either:

- wheel play detectors in the side to side mode, or
- rocking each wheel by hand or, where appropriate, with a bar in the wheel

Defect	Category
(a) A stub axle fractured.	Dangerous
(b) A stub axle swivel pin and/or bush:	
(i) excessively worn	Major
(ii) insecure or directional stability is impaired.	Dangerous
(c) Movement between the stub axle and axle beam:	
(i) is excessive	Major
(ii) is so excessive the stub axle is likely to become insecure or directional stability is impaired.	Dangerous
(d) A king pin:	
(i) loose in the axle beam	Major
(ii) so loose it is likely to affect directional stability.	Dangerous

### 5.1.3 Wheel bearings

The inspection of rear wheel bearings does not apply to vehicles with a DGW in excess of 5000kg.

Assess play in wheel bearings by either:

- rocking the wheels in turn while they are jacked clear of the ground, or
- using wheel play detectors in the side to side mode

Also, spin each wheel to check for noisy wheel bearings due to excessive roughness.

# 5 Axles, Wheels, Tyres and Suspension

Defect	Category
(a) A wheel bearing: (i) with excessive play (ii) play so excessive it is likely to break up or directional control impaired	Major Dangerous
(b) A wheel bearing: (i) excessively rough (ii) likely to collapse.	Major Dangerous

## 5.2 Wheels and tyres

### 5.2.1 Road wheel hub

Defect	Category
(a) A wheel: (i) with a loose or missing wheel nut, bolt or stud (ii) with more than one loose or missing wheel nut, bolt or stud.	Major Dangerous
(b) A spigot mounted wheel hub: (i) excessively worn or damaged (ii) worn or damaged to the extent that wheel security is adversely affected.	Major Dangerous

### 5.2.2 Wheels

**This inspection applies only to** the road wheels fitted to the vehicle at the time of the inspection. The vehicle presenter should be informed if a defect is noticed on a spare wheel.

**Removal of wheel hub caps etc.** is not permitted.

**Abutting ends are permissible** on detachable spring retaining rings on wheel rims of semi-drop centre type (identified by the ends of the ring shaped to interlock) provided the retainer is adequately and safely located in the wheel rim.

Defect	Category
(a) Any fracture or welding defect on a wheel.	Dangerous
(b) A tyre retaining ring: (i) not correctly fitted (ii) likely to come off.	Major Dangerous
(c) A wheel: (i) badly distorted or wear between wheel and hub at spigot mounting (ii) distorted or worn to the extent the wheel or tyre is likely to become detached	Major Dangerous
(d) A wheel and its fixings not compatible	Major

# 5 Axles, Wheels, Tyres and Suspension

## 5.2.3 Tyres

### Size

The **aspect ratio of a tyre** is included in the size marking. For example, a 215/55R15 has an aspect ratio of 55%.

“Standard” car tyres have a nominal aspect ratio of 82% (unless marked otherwise) and these are almost identical in size to tyres with an aspect ratio of 80% and can be safely mixed in any configuration on a vehicle.

**Some tyres may be marked with two sizes;** for example, a 185/75R14 tyre may be dual marked 185R14. In these circumstances either marking can be accepted.

### Load Rating

The check of tyre load rating only applies to Class 5 and 7 vehicles.

A tyre load rating table is in Appendix B.

The **permitted maximum laden weight of an axle** is that shown on the manufacturer’s plate. However, where axle weights are not displayed on the manufacturer’s plate, the load capacity of the tyres must be assumed suitable, unless there is indisputable evidence to the contrary.

If a goods vehicle is displaying a ‘Ministry’ plate showing lower axle weights not to be exceeded in Great Britain, these must be used instead of those shown on the manufacturer’s plate.

### Load Ratings for Low Speed Rated Tyres (Class 5 only)

Unless the vehicle is a ‘Restricted Speed Vehicle’ the tyres are required to be suitable for use up to the maximum prescribed speed limit of 70mph (‘L’ speed rating).

Tyres of the lower speed ratings of ‘J’ or ‘K’ however are acceptable for use at 70mph although the increase from the nominated speed rating imposes a reduction in the tyres’ carrying capacity. This allowance is only applicable to the nominal service markings (Load Index/Speed Symbol).

This allows a tyre displaying a ‘J’ speed rating (suitable for a maximum of 62mph) to be used at the ‘L’ speed (suitable for a maximum of 70mph) at the penalty of reducing the tyres capacity by 7%.

In the case of a tyre displaying a ‘K’ speed rating (suitable for a maximum of 68mph) a reduction in capacity of 3% is imposed to allow use up to the ‘L’ speed, for example:

146/143K= 6000kg single or 10900kg dual – at a maximum speed of 68mph

Less 3% = 5820kg single or 10580kg dual – at a maximum speed of 70mph

This would allow a tyre displaying the speed rating ‘K’ to be used on a vehicle to which a maximum prescribed speed limit of 70mph applies, subject to it being suitable at the reduced capacity of 5820kg in single and 10580kg in dual formation, for the maximum permitted axle weight of the axle to which it is fitted (the GB maximum permitted weight as shown on the manufacturer’s plate)

If a tyre of ‘J’ or ‘K’ speed rating is fitted to a vehicle subject to a maximum prescribed speed of 70mph and found to be below the weight capacity required, this is considered to be a defect.

### Structure

Tyres of different types of structure, such as radial-ply and cross-ply, cannot be mixed on the same axle.

Steel and fabric radial-ply tyres are to be regarded as the same structure type.

Run flat and conventional tyres may be mixed on the same axle, although this is not recommended.



# 5 Axles, Wheels, Tyres and Suspension

## Condition and Fitment

**Evidence of a tyre contacting** a part of the vehicle, such as due to tyre flexing or suspension movement, is not considered to be a defect. A vehicle should only be rejected if the tyre is actually fouling a part of the vehicle at the time of test. Some vehicles have lock stops comprising rubbing pads on the body that the front tyres may contact on a full lock. These are acceptable if they are properly maintained so that they do not damage the tyres.

**When assessing cuts in a tyre**, it is permissible to check whether a cut is deep enough to reach the ply or cord by using a blunt instrument to open the cut taking care not to cause further damage.

The following criteria should be used when assessing a cut in a tyre:

1. Any ply or cord that can be seen without touching the tyre – fail.
2. If by folding back rubber or opening a cut with a blunt instrument, so as not to cause further damage, exposed ply or cord can be seen irrespective of the size of the cut - fail.
3. If a cut which is more than 25mm or 10% of the section width whichever is the greater, is opened with a blunt instrument and cords can be felt but not seen - fail.

Before failing a cut as listed in 3 above, you must ensure that it is definitely the cords that are felt and not a foreign object. If there is any doubt then you should pass & advise.

**When assessing lumps or bulges** in a radial ply tyre, care should be taken to distinguish between normal undulations in the carcass, resulting from manufacturing, and lumps or bulges caused by structural deterioration.

**Stretched tyres** do not justify rejection in themselves, however, additional care should be taken when checking the condition of stretched tyres as they are more prone to sidewall damage.

**Recut tyres** are only permitted on vehicles over 3050kg ULW and:

- goods vehicles with an ULW of at least 2540kg having at least 16 inch (405mm) diameter wheels
- passenger vehicles with an ULW of at least 2540kg having 8 or more passenger seats.

## Tread Depth

**A tread pattern** is the combination of plain surfaces and grooves extending across the breadth of the tread and round the entire circumference. It excludes any tie-bars, tread wear indicators, or features designed to wear out substantially before the remainder of the pattern, and other minor features.

In simple terms, grooves containing tread wear indicators (TWI) or grooves cut as deep as those containing the wear indicators when new, are considered to be primary grooves. Other grooves or sipes that are not cut as deep as the primary grooves are secondary grooves and are not to be considered when assessing tread depth.

**The 'breadth of tread'** is the part of the tyre which can contact the road under normal conditions of use measured at 90 degrees to the peripheral line of the tread.

**Tyre tread depth requirements** are dependent on the vehicle type as detailed below:

### 1.6mm tread depth requirement

Applies to vehicles first used on or after 3 January 1933 that are either:

- a. Passenger vehicles with not more than 8 passenger seats, excluding the driver's seat.
- b. Goods vehicles or dual purpose vehicles not exceeding 3500kg DGW.
- c. Tricycles with an ULW exceeding 410kg and all quadricycles.

The primary grooves of the tread pattern must be at least 1.6mm within the central three-quarters of the breadth of tread and around the entire outer circumference of the tyre.

Either side of the central three-quarters of the tyre can be devoid of tread ('bald').

# 5 Axles, Wheels, Tyres and Suspension

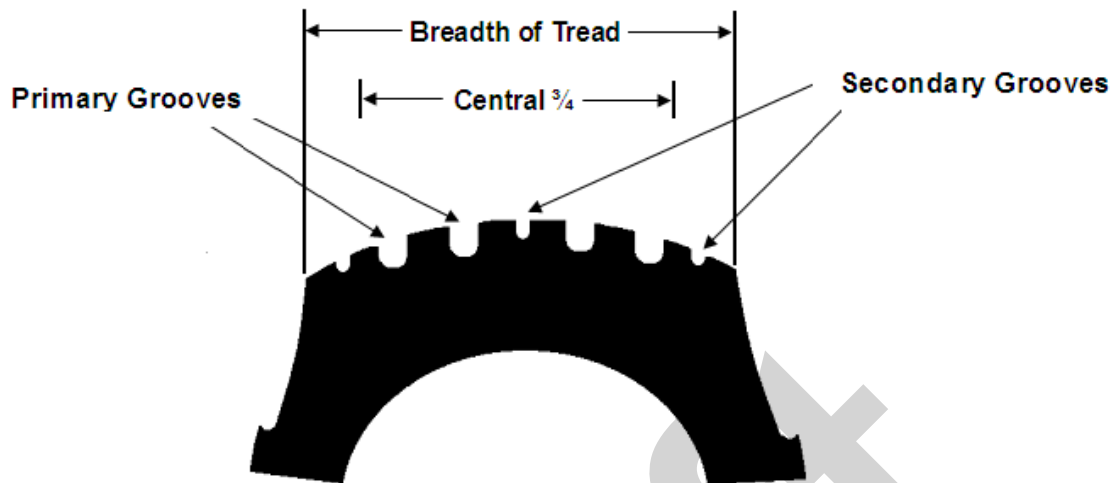

## 1.0mm tread depth requirement

Applies to:

- Vehicles first used before 3 January 1933
- Passenger vehicles with more than 8 passenger seats excluding the driver's seat.
- Tricycles with an ULW not exceeding 410kg with an engine capacity greater than 50cc.

The tread pattern must be visible over the whole tread area, and have a depth of at least 1.0mm throughout a single band of at least three-quarters over any section of the breadth of tread round the entire outer circumference of the tyre.

The 1.0mm tread depth requirement applies to the whole tread width if the original tread pattern did not extend beyond three-quarters of the tyre width when new.

There is no tread depth requirement for tricycles with an ULW not exceeding 410kg and an engine capacity not greater than 50cc. Such machines are only required to have clearly visible tread around the entire circumference and across the whole breadth of the tread.

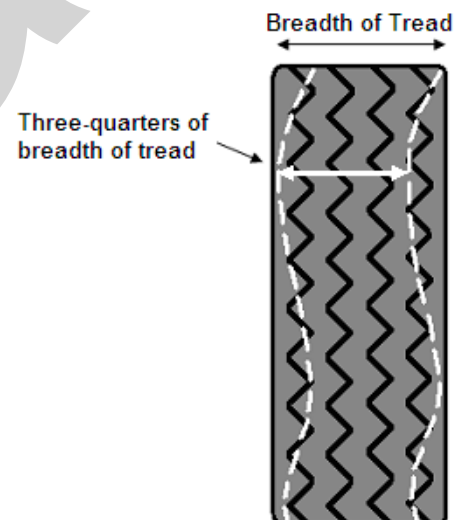

## Tyre Pressure Monitoring System (TPMS)

The inspection of the tyre pressure monitoring system (TPMS) only applies to M1 vehicles first used on or after 1 January 2012.

The check does not apply to quadricycles.

The **TPMS warning lamp** (as below) may operate in various ways depending on the vehicle type. Vehicles must only be rejected if it is clear that the lamp indicates a system malfunction and not simply indicating that one or more tyre pressures are low.



# 5 Axles, Wheels, Tyres and Suspension

Defect	Category
(a) A tyre: (i) load capacity or speed rating not in accordance with the minimum requirements (ii) load capacity insufficient for axle presented weight.	Major  Dangerous
(b) Tyres on the same axle or on twin wheels are different sizes.	Major
(c) Tyres on the same axle of different structure.	Major
(d) A tyre: (i) seriously damaged (ii) cords visible or damaged.	Major  Dangerous
(e) Tyre tread depth not in accordance with the requirements.	Dangerous
(f) A tyre fouling a part of the vehicle.	Major
(g) A recut tyre fitted to a vehicle not permitted to be fitted with recut tyres.	Major
(h) Tyre pressure monitoring system: (i) malfunctioning or tyre obviously under-inflated (ii) obviously inoperative.	Minor  Major

## 5.3 Suspension

### 5.3.1 Springs

**This inspection includes** bonded suspension units.

**On leaf spring type suspension**, when modified spring anchor or shackle brackets are fitted, if there are more mounting holes in the bracket than holes in the chassis, this is not a reason for rejection.

**Defect 5.3.1.b also applies to** that part of a leaf spring which is curled to prevent disengagement from a slipper.

**The security of a coil spring** to the chassis or axle should be assessed when jacking and lowering the vehicle. If the spring does not correctly locate when the suspension is returned to its normal running position then it should be rejected for being insecurely attached. There is no requirement to jack the rear wheels of vehicles with a DGW in excess of 5000kg.

**An unsafe modification** includes welded repairs or the use of excessive heat to highly stressed components (see Appendix A) and modifications which are likely to affect the roadworthiness of the vehicle.

# 5 Axles, Wheels, Tyres and Suspension

Defect	Category
(a) A spring: (i) insecurely attached to chassis or axle (ii) with fixings loose to the extent that relative movement is visible.	Major Dangerous
(b) A spring: (i) or spring component fractured or seriously weakened (ii) main leaf fractured.	Major Dangerous
(c) A spring: (i) missing (ii) missing and directional control affected	Major Dangerous
(d) A spring: (i) with an unsafe modification (ii) modified so that the suspension is inoperative.	Major Dangerous

## 5.3.2 Shock absorbers

A missing shock absorber should only be rejected where they were fitted as standard.

Defect	Category
(a) A shock absorber: (i) insecurely attached to chassis or axle (ii) missing or likely to become detached.	Major Dangerous
(b) A shock absorber damaged to the extent that it does not function or showing signs of severe leakage.	Major

## 5.3.3 Suspension arms, rods, struts, sub-frames, anti-roll bars etc.

Some vehicles use comparatively thin gauge steel pressings for some highly stressed suspension components. Many of these parts have hollow 'box sections' or up-facing areas where road dirt impregnated with salt or other chemicals collects and causes serious but often very local corrosion.

Special attention should be paid to these components.

Guidance on assessing corrosion is given at Appendix 'A'.

It may be easier to inspect suspension components with the wheels jacked for the checks in Section 5.3.4. There is no requirement to jack the rear wheels of vehicles with a DGW in excess of 5000kg.

# 5 Axles, Wheels, Tyres and Suspension

Defect	Category
(a) A suspension component: (i) insecurely attached to chassis or axle (ii) missing, likely to become detached or directional stability impaired.	Major Dangerous
(b) A suspension component: (i) excessively damaged or corroded (ii) fractured or likely to fail	Major Dangerous
(c) A suspension component: (i) with an unsafe modification (ii) modified so that the suspension is inoperative or likely to fail other components.	Major Dangerous

## 5.3.4 Suspension joints, pins and bushes

**Some rubber/synthetic bushes** are designed to provide a comparatively high degree of compliance and are therefore likely to show some movement. Such components should normally only be rejected when serious deterioration of the bonding or flexible material is evident.

**Many MacPherson strut top bushes** are designed to have significant lateral play when the suspension is hanging free. Rejection is only justified when play is due to wear and/or maladjustment, etc.

**Wear or play in spring pins and bushes** should be assessed using a small pinch bar. Wear may also be checked using wheel play detectors, where these are available. Wear should be regarded as excessive when there is play greater than:

- 2mm for a 12mm diameter pin
- 3mm for a 25mm diameter pin
- 10% of the pin diameter for pins over 25mm diameter

**To assess the condition of some front suspension** components it will be necessary to use wheel play detectors. If wheel play detectors are not available:

- jack the front wheels clear of the ground, place a suitable bar under each wheel in turn and lever upwards, looking for play in components
- on vehicles with front suspension systems that do not have the torsion bar or spring force acting on the lower suspension arm; with the front wheels resting on unlocked turning plates, grasp the top of each wheel and rock it vigorously in and out to check for play. This must be repeated, grasping the wheels at the 3 o'clock and 9 o'clock positions
- use an assistant to rock and shake the wheels while the tester examines the relevant items.

### Method of jacking

Vehicles with front suspension types that have the torsion bar or spring force acting on the lower suspension arm must be jacked under the lower suspension arm so that the suspension spring force is removed from the ball joints as shown.

Beam axles should be jacked under the beam.

All other suspension types must be jacked so the suspension hangs freely.

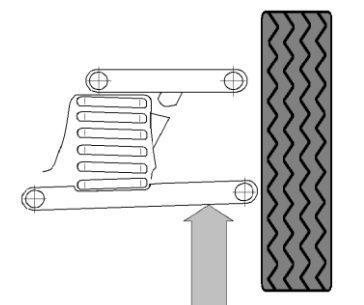

# 5 Axles, Wheels, Tyres and Suspension

Defect	Category
(a) A suspension pin, bush or joint: <ul style="list-style-type: none"> <li>(i) excessively worn</li> <li>(ii) likely to become detached.</li> </ul>	Major Dangerous
(b) A suspension joint dust cover: <ul style="list-style-type: none"> <li>(i) severely deteriorated</li> <li>(ii) missing or no longer prevents the ingress of dirt etc.</li> </ul>	Minor Major

## 5.3.5 Gas, Air and fluid suspension

Defect	Category
(a) A gas, air or fluid suspension system inoperative.	Dangerous
(b) A gas, air or fluid suspension system component damaged, modified or deteriorated in a way that: <ul style="list-style-type: none"> <li>(i) it would adversely affect the functioning of the system</li> <li>(ii) its function is seriously affected.</li> </ul>	Major Dangerous
(c) An obvious leak from any part of the system.	Major

## 5.3.6 Complete suspension system

**Guidance for assessing corrosion** is provided at Appendix 'A'.

**The condition of the main load bearing structure** not within a prescribed area is checked under Section 6.

Check the strength and continuity of the vehicle's load bearing members and their supporting structure or panelling around any spring, sub-frame or suspension component mounting.

Defect	Category
(a) The strength or continuity of the load bearing structure within 30cm of any sub-frame, spring or suspension component mounting (a 'prescribed area'): <ul style="list-style-type: none"> <li>(i) is significantly reduced or inadequately repaired.</li> <li>(ii) is so weakened that control of the vehicle is likely to be adversely affected.</li> </ul>	Major Dangerous

# 6 Body, Structure and Attachments

---

## Section 6 - Contents

### 6.1 Structure and Attachments

- 6.1.1 General condition
- 6.1.2 Exhaust system
- 6.1.3 Fuel system
- 6.1.4 Bumpers
- 6.1.5 Spare wheel carrier (if fitted)
- 6.1.6 Towbars
- 6.1.7 Transmission
- 6.1.8 Engine mountings

### 6.2 Body and Interior

- 6.2.1 Body condition
- 6.2.2 Cab and body mounting
- 6.2.3 Doors and door catches
- 6.2.4 Floor
- 6.2.5 Driver's seat
- 6.2.6 Passenger seats
- 6.2.7 Driving controls
- 6.2.8 Cab steps (if fitted)
- 6.2.9 Not in use
- 6.2.10 Not in use
- 6.2.11 Not in use
- 6.2.12 Handgrips and footrests

# 6 Body, Structure and Attachments

## 6.1 Structure and Attachments

### 6.1.1 General condition

**Guidance on assessing corrosion** is provided in Appendix 'A' of this Manual along with diagrams of a number of typical vehicle structures, where the shaded portions indicate the important load-bearing parts. The condition of 'prescribed areas' is checked under Sections 1, 2, 5 and 7 of this Manual.

Defect	Category
(a) A main load-bearing structural member:	
(i) fractured or deformed such that structural rigidity is significantly reduced.	Major
(ii) fractured or deformed such that steering or braking is likely to be adversely affected.	Dangerous
(b) Strengthening plates or fastenings:	
(i) insecure	Major
(ii) so insecure that structural rigidity is seriously reduced.	Dangerous
(c) Vehicle structure corroded to the extent that:	
(i) the rigidity of the assembly is significantly reduced	Major
(ii) steering or braking is likely to be adversely affected.	Dangerous

### 6.1.2 Exhaust system

**This inspection applies to** all vehicles with an internal combustion engine, including hybrid vehicles.

**The overall security of the exhaust system** should be assessed; one or more exhaust mountings missing may not justify rejection.

**Exhaust noise** is assessed under Section 8.1.1.

**The presence of catalytic converters** and diesel particulate filters is assessed under Section 8.2.

Defect	Category
(a) Exhaust system leaking or insecure.	Major
(b) Exhaust fumes:	
(i) entering cabin	Major
(ii) causing a danger to health of persons on board.	Dangerous

### 6.1.3 Fuel system

**This inspection applies to** all vehicles with an internal combustion engine or a hydrogen fuel cell.

**It may be necessary to open** the luggage compartment to carry out a full inspection of the fuel system.

**If a fuel tank is seen to be holed**, or the filler neck is seen to split it should be considered to be leaking even a leak may not be evident because the defect is above the fuel line.

**If access cannot be gained to the fuel filler cap** see 'Refusal to Test' in the Introduction to this Manual.

**On gas powered vehicles**, the presence of a leak must be confirmed by the use of a leak detection product conforming to BS EN 14291-2004. Leak detection products must be used in accordance with the manufacturer's instructions.



# 6 Body, Structure and Attachments

Defect	Category
(a) Fuel tank, pipe or hose; (i) insecure (ii) insecure such that there is a risk of fire.	Major Dangerous
(b) Fuel system: (i) leaking, or missing or ineffective filler cap (ii) leaking excessively or a risk of fire.	Major Dangerous
(c) Fuel pipe or hose: (i) chafing (ii) damaged.	Minor Major
(d) Not in use	
(e) Fire risk due to fuel tank shield or exhaust shield missing where fitted as original equipment.	Dangerous
(f) Any part of an LPG/CNG/LNG or hydrogen system defective.	Dangerous

## 6.1.4 Bumpers

Defect	Category
(a) Bumper: (i) insecure or with damage likely to cause injury when grazed or contacted (ii) likely to become detached.	Major Dangerous

## 6.1.5 Spare wheel carrier (if fitted)

**This inspection only applies to** externally mounted spare wheel carriers.

Defect	Category
(a) A spare wheel carrier fractured or insecure.	Major
(b) A spare wheel: (i) insecure in carrier (ii) likely to become detached.	Major Dangerous

## 6.1.6 Coupling mechanisms and towing equipment

**This inspection applies to all types of coupling mechanisms** and towbars fitted to the rear of a vehicle, including fifth-wheel couplings. It does not include emergency towing eyes. Tow ball covers must be removed to facilitate inspection of the tow ball.

**Some coupling mechanisms may be behind an access panel** in the bumper, bodywork or removable cover on a pick-up type vehicle. Unless requiring the use of tools or specialist equipment, these panels must be removed to facilitate the inspection of coupling components, as well as checking inside the luggage compartment where appropriate, including lifting of loose fitting mats or carpet.

# 6 Body, Structure and Attachments

**Retractable towbars** should be tested in their 'in-use' position unless this requires the use of tools or specialist equipment.

If a **tow ball or pin is not fitted at the time of test**, because it is detachable, has been unbolted or otherwise removed, but the attachment brackets are still in place, these brackets should still be assessed unless they have been deliberately rendered unfit for further use.

**There may be play in some detachable tow balls** between the receiver socket and the tapered swan neck fitting, with up to 3mm movement measured at the ball end.

**Wear in a pin, jaw or hook** should be regarded as excessive if the thickness of the metal at any point is reduced by more than 25% of the original thickness. Pin locating holes should be rejected if they are worn or elongated by more than 25% of their original diameter.

For tow balls the amount of acceptable wear is considerably less. However, a tow ball should only be rejected if a visual assessment indicates that the tow ball is obviously excessively worn.

**Many 'bolt-on' type tow balls** have accessory devices sandwiched between the tow ball and its mounting flange. These are not to be considered as inappropriate modifications unless their fitment is clearly likely to adversely affect the roadworthiness of the vehicle/trailer combination.

Defect	Category
(a) A towbar component damaged, defective or fractured.	Major
(b) A towbar component: (i) excessively worn (ii) so worn it is likely to fail.	Major Dangerous
(c) A towbar attachment: (i) defective or insecure (ii) likely to become detached.	Major Dangerous
(d) A towbar safety device damaged or not operating correctly.	Major
(e) A towbar coupling indicator not working.	Major
(f) Towbar (i) obstructing the registration plate or any lamp (ii) obstructing the registration plate so that it is unreadable.	Minor Major
(g) Unsafe modification: (i) to towbar secondary components (ii) to towbar primary components.	Major Dangerous
(h) Coupling too weak.	Major
(i) The strength or continuity of the load bearing structure within 30cm of any towbar mounting bracket: (i) is significantly reduced (ii) is so weakened that the towbar is likely to become detached.	Major Dangerous

## 6.1.7 Transmission

**This inspection applies to** all prop shafts and drive shafts as well as their couplings or bearings. The inspection also includes checks of drive chains or belts.

**The inspection does not apply to** Class 3 vehicles.

# 6 Body, Structure and Attachments

Defect	Category
(a) A transmission shaft: (i) securing bolts loose or missing (ii) likely to become detached.	Major Dangerous
(b) A transmission shaft bearing: (i) excessively worn (ii) likely to break up.	Major Dangerous
(c) A transmission: (i) joint, belt or chain excessively worn (ii) so worn it is likely to fail.	Major Dangerous
(d) A transmission shaft flexible coupling: (i) excessively deteriorated (ii) so deteriorated it is likely to fail.	Major Dangerous
(e) A transmission shaft bent or badly damaged.	Major
(f) A transmission shaft bearing housing: (i) fractured or insecure (ii) likely to fail.	Major Dangerous
(g) A transmission shaft constant velocity joint boot: (i) severely deteriorated (ii) missing or no longer prevents the ingress of dirt etc.	Minor Major

## 6.1.8 Engine mountings

**This inspection applies to** all vehicles other than Class 3.

**The inspection includes mountings** bolted to the gearbox that provide essential support for the engine.

**Body corrosion** in the vicinity of an engine mounting should only be rejected if it is so severe that it results in excessive movement.

Defect	Category
(a) A engine mounting or bracket: (i) severely damaged or deteriorated resulting in excessive movement (ii) fractured, missing or excessively loose.	Major Dangerous

## 6.2 Body and interior

### 6.2.1 Body condition

**This inspection applies to** all vehicles and includes all body panels as well components such as undertrays, spoilers and mirror housings. The inspection of bumpers is at Section 6.1.4.

**A 'body pillar'** applies only to the load carrying area of a goods vehicle.

**An unsafe modification** is one that is likely to cause injury.

# 6 Body, Structure and Attachments

Defect	Category
(a) A body panel or body component: <ul style="list-style-type: none"> <li>(i) damaged or corroded and likely to cause injury when grazed or contacted, or insecure</li> <li>(ii) likely to become detached.</li> </ul>	Major Dangerous
(b) A body pillar: <ul style="list-style-type: none"> <li>(i) insecure</li> <li>(ii) so insecure that load stability or security likely to be seriously impaired.</li> </ul>	Major Dangerous
(c) The passenger compartment in such a condition that: <ul style="list-style-type: none"> <li>(i) it permits the entry of exhaust fumes</li> <li>(ii) exhaust fumes lead to a danger to health of persons on board.</li> </ul>	Major Dangerous
(d) Body: <ul style="list-style-type: none"> <li>(i) has an unsafe modification</li> <li>(ii) modification likely to adversely affect braking or steering.</li> </ul>	Major Dangerous
(e) A bootlid, tailgate, dropside, loading door or access panel cannot be secured in the closed position.	Major

## 6.2.2 Cab and body mounting

**This inspection only applies** to those vehicles with a separate body and/or cab. Cabs and cab mountings are not testable on Class 3 vehicles.

**The condition of the body/cab and chassis** should be assessed for corrosion within 30cm of the mountings. Cab/body mountings are NOT prescribed areas and therefore rejection is only justified if the overall security is significantly reduced.

**Individual body or cab security defects** do not justify rejection unless their cumulative effect is likely to significantly reduce the overall security of the body or cab.

Defect	Category
(a) A body or cab: <ul style="list-style-type: none"> <li>(i) insecure</li> <li>(ii) insecure to the extent that stability is seriously impaired.</li> </ul>	Major Dangerous
(b) A body or cab obviously not squarely located on chassis.	Major
(c) Body or cab mounting: <ul style="list-style-type: none"> <li>(i) fixings missing or insecure such that overall security is significantly reduced</li> <li>(ii) fixings missing or insecure such that stability is seriously impaired.</li> </ul>	Major Dangerous
(d) Body, cab or chassis: <ul style="list-style-type: none"> <li>(i) excessively corroded at mounting points</li> <li>(ii) corroded at mounting points to the extent that overall security or stability is seriously impaired.</li> </ul>	Major Dangerous

# 6 Body, Structure and Attachments

## 6.2.3 Doors and door catches

The inspection of doors does not apply where a door was not fitted as part of the original design of the vehicle. Similarly, a lack of door handles because of original design characteristics or specialist modification is not considered to be a defect provided the door can be latched securely in the closed position.

The driver's and all passenger doors must be able to be opened from outside. Drivers and front passenger doors must also be able to be opened from inside, using the relevant control in all cases.

The only requirement for load space doors is that they can be secured in the closed position.

Door hinges, catches and pillars should only be rejected for deterioration if door operation is adversely affected.

Defect	Category
(a) A door will not open using the relevant control or close properly.	Major
(b) A door likely to open inadvertently or not remain closed: <ul style="list-style-type: none"> <li>(i) in the case of a sliding door</li> <li>(ii) in the case of a hinged door</li> </ul>	Major Dangerous
(c) A door hinge, catch or pillar: <ul style="list-style-type: none"> <li>(i) excessively deteriorated</li> <li>(ii) missing or insecure.</li> </ul>	Minor Major

## 6.2.4 Floor

This inspection applies to the floor in driver, passenger and goods carrying compartments.

Areas of the floor within a 'prescribed area' are not included in this inspection.

Defect	Category
(a) A floor: <ul style="list-style-type: none"> <li>(i) excessively deteriorated or insecure</li> <li>(ii) so deteriorated or insecure it is likely to cause loss of control of the vehicle, injury, load insecurity or instability.</li> </ul>	Major Dangerous

## 6.2.5 Driver's seat

When checking the driver's seat adjustment it is not necessary to check that the seat can be secured in all possible positions. In the case of electrically adjusted seats, it is not necessary to check that any 'memory position' function is working.

Defect	Category
(a) A driver's seat: <ul style="list-style-type: none"> <li>(i) with a defective structure</li> <li>(ii) insecure.</li> </ul>	Major Dangerous
(b) A driver's seat: <ul style="list-style-type: none"> <li>(i) fore and aft adjustment mechanism not working as intended</li> <li>(ii) seat moving inadvertently or backrest cannot be retained in the upright position.</li> </ul>	Major Dangerous

# 6 Body, Structure and Attachments

## 6.2.6 Passenger seats

**Every effort should be made to lift folded seats** to facilitate the inspection of seat belts provided this does not require the use of tools or specialist equipment. Where the seats cannot be lifted due to the presence of heavy, fragile or numerous passenger effects or other articles, refuse to test the vehicle as per item 4d in the Introduction.

**A passenger seat** should only be considered defective if it is likely to cause injury.

Defect	Category
(a) A passenger seat:	
(i) with a defective structure or the backrest cannot be retained in the upright position.	Major
(ii) insecure.	Dangerous

## 6.2.7 Driving controls

**This inspection only applies to** Class 5 vehicles and includes those driving controls not covered in other sections of the Manual, for example; clutch, accelerator, gear selector, engine stop etc.

Defect	Category
(a) A driving control necessary for the safe operation of the vehicle:	
(i) not functioning correctly	Major
(ii) not working or functioning such that safe operation of the vehicle is affected.	Dangerous

## 6.2.8 Cab steps

**This inspection only applies to** those vehicles fitted with steps to aid entry into the driver's and/or the front passenger compartment.

Defect	Category
(a) A cab step or step ring:	
(i) insecure	Minor
(ii) so insecure that it is likely to cause injury.	Major
(b) A cab step or step ring in such a condition that it is likely to cause injury.	Major

## 6.2.9 Not in use

## 6.2.10 Not in use

## 6.2.11 Not in use

## 6.2.12 Handgrips and footrests

**This inspection only applies to** vehicles fitted with handgrips and/or footrests for the driver/passenger(s). They must only be rejected where it is clear that they are required for the safe operation of the vehicle.

# 6 Body, Structure and Attachments

Defect	Category
(a) A handgrip or footrest missing or insecure.	Major

Draft

# 7 Other Equipment

---

## Section 7 - Contents

### 7.1 Seat Belts and Supplementary Restraint Systems (SRS)

- 7.1.1 Seat belt security
- 7.1.2 Seat belt fitment and condition
- 7.1.3 Seat belt load limiters
- 7.1.4 Seat belt pre-tensioners
- 7.1.5 Airbags
- 7.1.6 SRS malfunction indicator lamp (MIL)

### 7.2 Not in use

### 7.3 Anti-theft Device

### 7.4 Not in use

### 7.5 Not in use

### 7.6 Not in use

### 7.7 Audible Warning (Horn)

### 7.8 Speedometer

### 7.9 Not in use

### 7.10 Speed limiter (if required)

### 7.11 Not in use

### 7.12 Electronic Stability Control (ESC)



# 7 Other Equipment

## 7.1 Seat Belts and Supplementary Restraint Systems (SRS)

### 7.1.1 Seat belt security

**This inspection applies to** all seat belts fitted, including child seats/restraints etc., that are permanently attached to the vehicle using Isofix mountings or nuts, bolts etc. Additionally, anchorages for the securing of disabled persons belts or wheelchairs are also subject to the requirements.

**A seat belt anchorage 'prescribed area'** includes the seat mounting points where a seat belt is attached to a seat frame. Guidance for assessing corrosion and use of the corrosion assessment tool is provided at Appendix 'A'.

**Where a belt is fitted with no corresponding seat** or if there is a buckle/stalk but no corresponding belt, it is NOT to be considered a seat belt for the purpose of this inspection.

Defect	Category
(a) A seat belt:	
(i) load bearing structure strength or continuity significantly reduced within 30cm of an anchorage point (see Appendix 'A')	Major
(ii) anchorage likely to become detached in the event of a collision.	Dangerous
(b) Seat belt anchorage loose.	Major

### 7.1.2 Seat belt fitment and condition

**This inspection applies to all seat belts fitted**, including child seats/restraints etc. Child seat(s) retained by seat belt(s) must not be removed. A visual examination is required of only those parts of the seat belt(s) which are readily accessible.

**Every effort should be made to lift folded seats** to facilitate the inspection of seat belts provided this does not require the use of tools or specialist equipment. Where the seats cannot be lifted due to the presence of heavy, fragile or numerous passenger effects or other articles, refuse to test the vehicle (item 4d in the Introduction).

**Where a belt is fitted with no corresponding seat**, it is NOT to be considered a seat belt for the purpose of this inspection.

**When checking the operation of the buckle**, fasten each belt locking mechanism and try to pull the locked sections apart. Then operate the release mechanism while pulling on the belt to check that the mechanism releases when required.

**On retracting seat belts**, check that with the mechanism fastened and the seat unoccupied, excess webbing is wound into the retracting unit. In doubtful cases, this should be checked with the seat base set in its rearmost position.

Some types of retracting belt might need manual help before they retract. Where a temporary device is fitted to prevent retraction, the NT may remove it at their discretion.

**A seat belt installation check** may be required on vehicles, fitted with more than 8 passenger seats, first used before 1 October 2001. Refer to Section 10 for further information.

#### Fitment

**To determine the requirements** for a particular vehicle refer to the relevant tables in Appendix 'C' in conjunction with the following notes. Unless stated, seats are not required to be fitted with seat belts.

**Passenger seats** are those designated for normal use when the vehicle is travelling on the road. Seating arrangements only intended for use when the vehicle is stationary (e.g. a sofa in the living area of a motor caravan) are not required to have seat belts.

**Side facing seats** are not required to be fitted with seat belts.

# 7 Other Equipment

**Occasional seats** that fold down when not in use are not required to be fitted with seat belts. Care must be taken in assessing whether seats are, by manufacture, intended for everyday use with the ability to be folded for extra luggage space or intended for occasional use.

Defect	Category
(a) A statutory seat belt missing.	Major
(b) A seat belt: (i) or flexible stalk damaged (ii) webbing or flexible stalk significantly stretched or weakened.	Major Dangerous
(c) Seat belt not functioning as intended or of an incorrect type.	Major
(d) Seat belt buckle missing, damaged or not functioning as intended.	Major
(e) Seat belt retractor not functioning as intended.	Major

## 7.1.3 Seat belt load limiters

**This inspection applies to** all seat belt load limiters fitted as original equipment other than on Class 3 vehicles.

**Load limiters** are designed to minimise seat belt inflicted injury in violent collisions. The simplest type of load limiter is a fold sewn into the belt webbing, which pulls apart when a high amount of force is applied to the belt.

Mechanical load limiters commonly use a torsion bar in the retractor mechanism. These cannot usually be readily inspected.

Defect	Category
(a) A seat belt load limiter fitted as original equipment obviously missing or a folded webbing type load limiter deployed.	Major

## 7.1.4 Seat belt pre-tensioners

**This inspection applies to** all seat belt pre-tensioners fitted as original equipment other than on Class 3 vehicles.

**Seat belt pre-tensioners** activate in certain violent collisions to tighten the seat belt just before the full force of impact. Once activated, a warning device may display.

Defect	Category
(a) A seat belt pre-tensioner fitted as original equipment obviously missing or deployed.	Major

## 7.1.5 Airbags

**This inspection applies to** all airbags fitted as original equipment other than on Class 3 vehicles.

**A passenger airbag** that is switched off is not a defect.

# 7 Other Equipment

Defect	Category
(a) An airbag fitted as original equipment obviously missing.	Major
(b) Not in use.	N/A
(c) An airbag obviously inoperative.	Major

## 7.1.6 Supplementary Restraint System (SRS)

Defect	Category
(a) An SRS malfunction indicator lamp (MIL) indicates a system malfunction.	Major

## 7.2 Not in use

## 7.3 Anti-theft device

**The inspection of the anti-theft device only applies to M1 vehicles** first used on or after 1 September 2001 and with not more than 8 passenger seats excluding the driver's seat. The check is also restricted to vehicles fitted with a steering lock as an anti-theft device as original equipment.

**The check does not apply to quadricycles.**

**Some electronic steering locks**, generally on vehicles with keyless ignition systems, will only activate when the driver's door is opened/closed.

**Where it is not practical** to ascertain the correct functioning of a steering lock the benefit of the doubt should be given.

Defect	Category
(a) Steering lock missing or not functioning.	Minor
(b) Steering lock inadvertently engaging.	Dangerous

## 7.4 Not in use

## 7.5 Not in use

## 7.6 Not in use

## 7.7 Audible warning (Horn)

**An audible warning** must be loud enough to be heard by other road users. It must not be a gong, bell or siren, nor have more than one tone.

**On vehicles first used on or after 1 August 1973**, the sound emitted must be a continuous or uniform note and not harsh or grating.

**On vehicles first used before 1906** the audible warning can be a gong, bell or siren.

# 7 Other Equipment

Defect	Category
(a) Audible warning: (i) not working properly (ii) inoperative.	Minor Major
(b) Audible warning control insecure.	Minor
(c) Audible warning: (i) sound not in accordance with requirements (ii) sound likely to be confused with an emergency vehicle siren.	Minor Major

## 7.8 Speedometer

**This inspection applies to** vehicles first used on or after 1 October 1937 having a maximum speed exceeding 25 mph other than Class 3 vehicles.

**If a road test is required**, for instance to carry out a decelerometer test, the operation of the speedometer must be checked whilst driving. Otherwise, it should only be rejected if it is obviously not operational.

**There is no requirement for a speedometer to illuminate** on vehicles with no front or rear position lamps or that have such lamps permanently disconnected, painted over or masked.

**A tachograph is an acceptable alternative** to a speedometer providing it satisfies the requirements of this inspection

Defect	Category
(a) Speedometer not fitted where one is required.	Major
(b) Speedometer: (i) operation impaired (ii) not working.	Minor Major
(c) Speedometer: (i) not sufficiently illuminated (ii) not illuminated.	Minor Major

## 7.9 Not in use

## 7.10 Speed limiter (If required)

**This inspection is confined to** those parts that are readily visible without dismantling and applies to all vehicles required to be fitted with a speed limiter.

These are:

- a. Vehicles with more than 8 passenger seats with a maximum speed in excess of 100km/h (62.14mph) if a speed limiter were not fitted, with a DGW not exceeding 7500kg and first used on or after 1 January 2005.
- b. Vehicles with more than 8 passenger seats with a maximum speed in excess of 100km/h (62.14mph) if a speed limiter were not fitted, with a DGW exceeding 7500kg and first used on or after 1 January 1988.

# 7 Other Equipment

- c. Vehicles with more than 16 passenger seats with a maximum speed in excess of 112.65km/h (70mph) if a speed limiter were not fitted, with a DGW exceeding 7500kg and first used between 1 April 1974 and 31 December 1987.

**Additionally, vehicles with a DGW not exceeding 7500kg with Euro III (or later) engines, first used between 1 October 2001 and 31 December 2004 are required to be fitted with a speed limiter. Specific identification of these vehicles is not required; however, if it is obvious that a speed limiter is fitted then it must meet the requirements of this inspection.**

**Some vehicles may have been modified**, such as by changing the rear axle ratio, and will no longer be capable of exceeding 100km/h. Where such a claim is made, a signed declaration stating the specific reason must be produced (for example, a low ratio axle fitted).

**Speed limiters wired through 'ignition switches'** are acceptable but any other devices that could enable the speed limiter to be switched off while driving are not.

**Tamperproof devices** may also take the form of mechanical and electrical connections that require the use of special tools normally only available from vehicle/component manufacturers for disconnection or adjustment purposes. These are acceptable instead of other types of tamperproof devices such as seals, lock nuts, pins, wires, plastic inserts, sealing compound or sealing paint on mechanical and electrical connections.

**Modern tamperproof devices** are electronic and therefore not possible to check.

**A vehicle's DGW** should be taken from the manufacturer's plate. For vehicles first used before 1 April 1982 not fitted with a manufacturer's plate, multiply the maximum number of passengers and crew, excluding the driver, by 63.5kg and add the kerb or unladen weight displayed on the side of the vehicle to obtain the calculated laden weight, which should be used instead.

**A speed limiter plate** must be securely fixed in the driver's compartment in a conspicuous position. If the plate is fixed to the driver's compartment window it is acceptable for the details to face inwards or outwards, provided that exterior facing plates can be read by a person of average height.

**The plate must be clearly and indelibly marked** with the speed at which the speed limiter has been set (the speed may be shown in mph or km/h). The character and composition of the plate and size of lettering are not important provided the details are legible.

Defect	Category
(a) Speed limiter not fitted in accordance with the requirements.	Major
(b) Speed limiter obviously not operational.	Major
(c) Speed limiter with an incorrect set speed.	Major
(d) Speed limiter tamperproof device missing or defective.	Major
(e) Speed limiter plate missing or illegible.	Major

## 7.11 Not in use

## 7.12 Electronic Stability Control

**This inspection applies to** all vehicles fitted with electronic stability control other than on Class 3 vehicles.

**Electronic stability control** may be known by a wide variety of acronyms including ESC; ESP; VDC, DSC etc. Some systems may be able to be switched off by a switch, whilst others may only be able to be switched off via an electronic menu system.

# 7 Other Equipment

The dashboard warning lamp for these systems may take various forms and a vehicle should only be failed where the tester is certain that the warning lamp is indicating an ESC malfunction. This may require reference to the owners handbook if one is available.

Defect	Category
(a) Wheel speed sensors missing or damaged.	Major
(b) ESC wiring damaged.	Major
(c) Other ESC component missing or damaged.	Major
(d) ESC switch damaged or not functioning correctly.	Major
(e) ESC MIL indicates a system malfunction.	Major

Draft

---

**Section 8 - Contents****8.1 Noise**

8.1.1 Noise suppression system

**8.2 Exhaust Emissions**

8.2.1 Spark ignition engine emissions

8.2.1.1 Exhaust emission control equipment

8.2.1.2 Gaseous emissions

8.2.2 Compression ignition engine emissions

8.2.2.1 Exhaust emission control equipment

8.2.2.2 Opacity

**8.3 Not in use****8.4 Other Environmental Items**

8.4.1 Fluid leaks

Draft

# 8 Nuisance

## 8.1 Noise

### 8.1.1 Noise suppression system

**This inspection applies to** all exhaust silencers and under-bonnet noise deadening material fitted as original equipment. The inspection of noise deadening material does not apply to Class 3 vehicles.

**Exhaust noise should be subjectively assessed** whilst carrying out the emissions test relevant for the vehicle. For vehicles not subject to an emissions test, the engine should be revved to around 2500rpm or approximately half maximum engine speed if this is lower.

**The exhaust system and silencer** should be in such condition, or of such a type, that the noise emitted from the vehicle is not clearly unreasonably above the level expected from a similar vehicle with a standard silencer in average condition.

Defect	Category
(a) Exhaust noise levels in excess of those permitted.	Major
(b) Any part of the noise suppression system:	
(i) insecure	Major
(ii) likely to become detached.	Dangerous

## 8.2 Exhaust emissions

### 8.2.1 Spark ignition engine emissions

#### 8.2.1.1 Exhaust emission control equipment

**This inspection only applies to** vehicles requiring a full catalyst emissions test (disregarding the Basic Emissions Test) and is restricted to components that are readily visible and identifiable, such as catalytic converters, oxygen sensors, exhaust gas recirculation valves etc.

Defect	Category
(a) Emission control equipment fitted by the manufacturer: missing, obviously modified or obviously defective.	Major
(b) An induction or exhaust leak that could affect emissions levels.	Major

#### 8.2.1.2 Gaseous emissions

**This inspection applies to** spark ignition engine vehicles first used on or after 1 August 1975, with the exception of Class 3 vehicles, 'L' category vehicles, electric/combustion engine (hybrid) vehicles and hydrogen fuel cell vehicles.

**Two stroke engines** do not require an emissions test unless they are subject to a catalyst test.

**Vehicles first used before 1 September 2002 fitted with a different engine** must be tested to the requirements of whichever is older, the engine or the vehicle. For example; a 1995 car fitted with a 1991 engine (of whatever make), must be tested to 1991 standards for emission purposes. The onus is on the vehicle presenter to prove engine age.

**Vehicles first used on or after 1 September 2002 fitted with a different engine** must be tested to the requirements relating to the age of the vehicle.

**If an engine has been modified** in any way, it still has to meet the exhaust emission requirements according to the age of the vehicle.



# 8 Nuisance

**For emissions purposes only** the following are to be considered first used before 1 August 1975:

- Kit cars and amateur built vehicles first used before 1 August 1998
- Wankel rotary engined vehicles first used before 1 August 1987
- All Q plated vehicles.

**Kit cars and amateur built vehicles first used on or after 1 August 1998** are required to obtain either Single Vehicle Approval (SVA) or Individual Vehicle Approval (IVA) and should be tested to the limits stated on the vehicles registration document (V5c). Where no limits are stated on the registration document, normal limits must be applied relative to the vehicles date of first use.

**Personal imports must be tested according to its date of first use**, unless a letter from the vehicle manufacturer is presented which states that the particular engine as originally installed could not meet the equivalent British emission standards.

In such cases, test to the next lower emission standard; for example, a 1995 car first used in Africa with a letter from the engine manufacturer stating that the particular engine (engine number to be stated) cannot meet catalyst emission limits, then use the non-cat limits of CO 3.5%, HC 1200ppm.

**A few vehicles may never have been able to meet the MOT limits** and regulations do not require vehicles to achieve CO or HC readings better than the original capability of the engine when new.

Where the presenter claims that this is the case, and can provide supporting evidence, such as a letter from the vehicle manufacturer, the vehicle should be considered exempt from the CO and HC emission requirements.

If the owner does not have sound supporting evidence, a Test Certificate should be refused.

**A “passenger car”, for emissions purposes**, is one that is constructed or adapted for the carriage of passengers; has no more than five seats in addition to the driver; has a maximum gross weight not exceeding 2500kg and is not a “goods vehicle” e.g. car derived van, pick up etc.

To determine whether a vehicle is a ‘Passenger car’, obtain the DGW from the manufacturers VIN plate, or:

- check if the vehicle is listed only in Section 2 of the current emissions data book
- use any other readily available data, such as the owners handbook or a data book
- if still unsure, assume it to be over 2500kg DGW

**Specialist conversions** are to be treated, for emissions purposes, as if they had not been converted. For example; a motor caravan or ambulance converted from a goods vehicle is still to be treated as not being a “passenger car”, whereas an ambulance converted to a goods vehicle, or a “passenger car” with seats added is still to be treated as being a “passenger car”.

Similarly, a vehicle originally built with 6 or more seats, in addition to the driver, which has had seats removed is still to be treated as not being a “passenger car”.

**To prevent the build-up of fumes**, the test should be carried out in a well ventilated area.

**A dual exhaust system** has two separate pipes from the engine manifold to the tailpipes. Even if there is a balance tube between the separate pipes it is still considered a dual exhaust. In these circumstances the emissions from the tailpipes should be averaged.

Averaging the emissions is done by adding together the readings and dividing by two, for example:

1st pipe emits 0.3% CO and 200 ppm HC

2nd pipe emits 0.1% CO and 150 ppm HC

$$\text{Average CO reading is: } \frac{0.3 + 0.1}{2} = 0.2\%$$

$$\text{Average HC reading is: } \frac{200 + 150}{2} = 175 \text{ ppm}$$

# 8 Nuisance

**Where a vehicle has an exhaust holed** to the extent that MOT failure is warranted, the emissions should be rechecked when the exhaust is repaired even if the vehicle does not leave the testing station in the meantime. Owners should be made aware that any emission readings taken with a leaking exhaust might be incorrect.

**Vehicles which run on more than one fuel**, such as petrol and LPG, should be tested on the fuel they are running on when presented.

**On vehicles running on LPG:** the hydrocarbons emitted are propane rather than hexane. The HC reading obtained must therefore be divided by the “propane/hexane equivalency factor” (PEF) marked on the gas analyser. For example: If the HC reading = 180 ppm and the PEF marked on the machine is 0.48.

The actual MOT value is  $\frac{180}{0.48} = 375$

**Use the flowcharts within this section** to establish which type of emission test is applicable to the vehicle being tested. The flowcharts and notes must be carefully followed as early catalyst equipped vehicles may not require a ‘CAT’ test.

**Some vehicles give unstable readings** due, for example, to their carburettor or fuel injection system design. Before failing a vehicle, it is important to establish that a particular limit has been exceeded constantly for a period of 5 seconds.

## Emissions limits - Vehicles first used on or after 1 August 1975

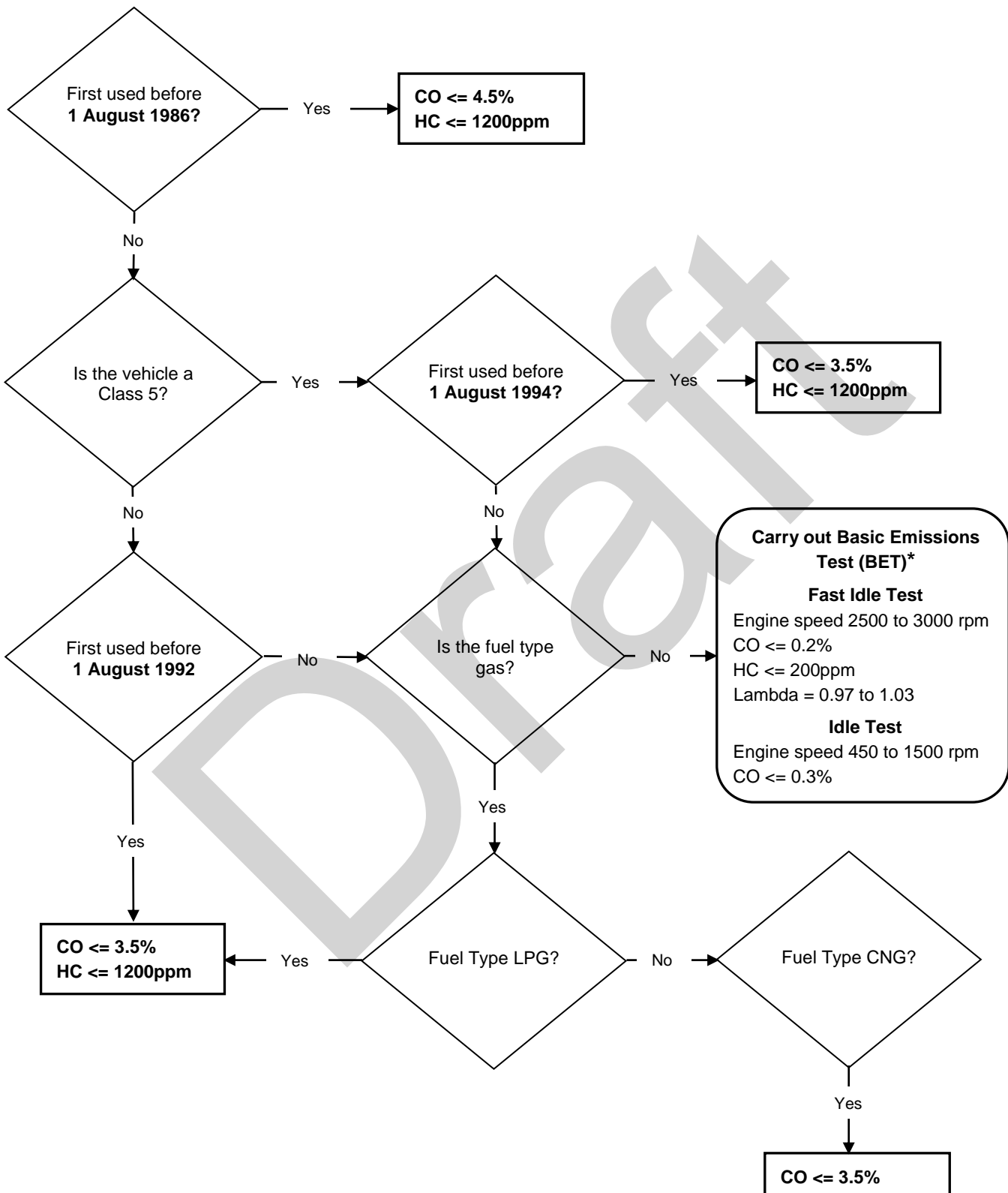

\*See flow chart for Passenger Cars first on or after 1 August 1992

## Emissions Limits Passenger Cars first on or after 1 August 1992

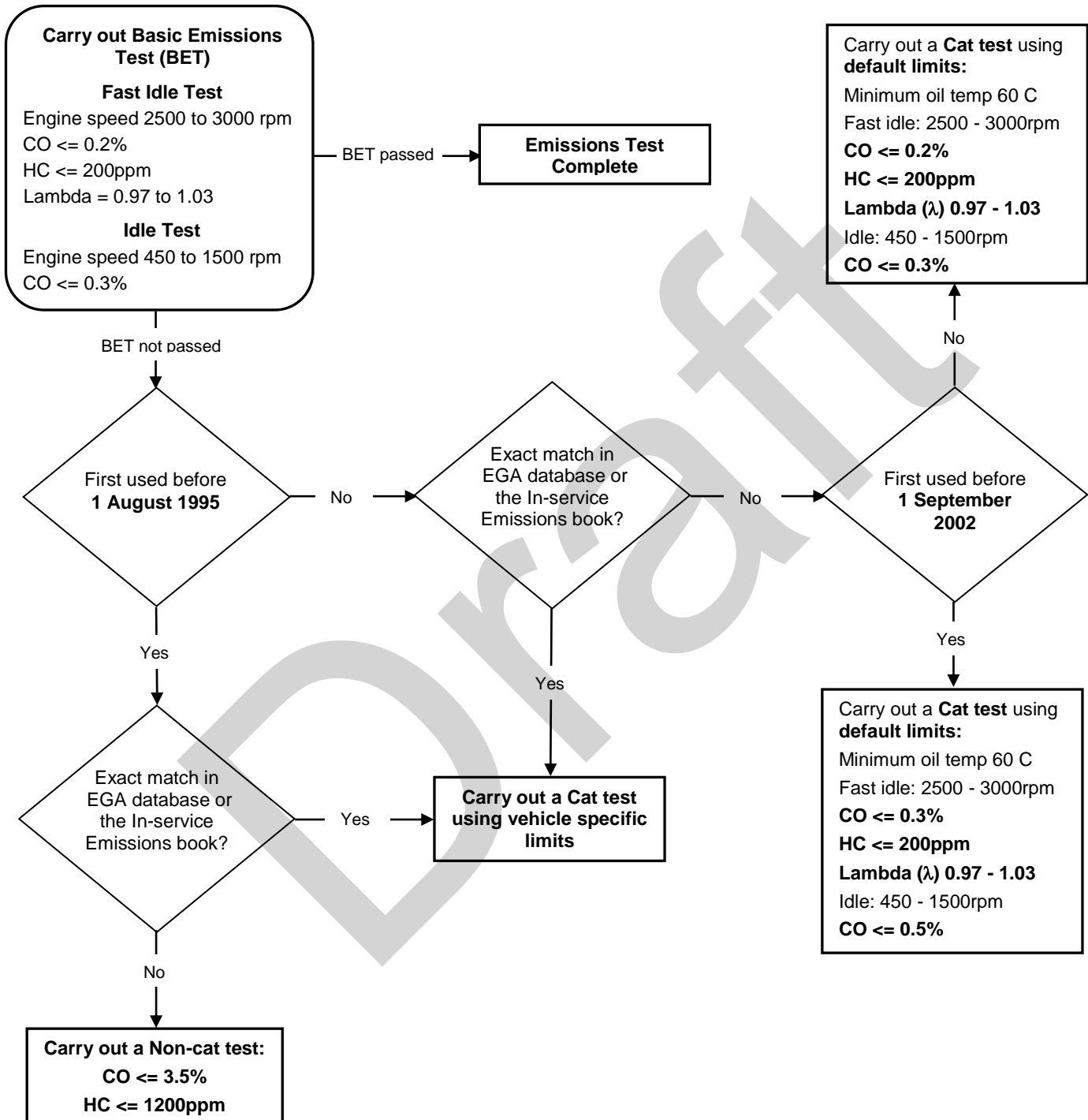

## Emissions Limits

### Non-Passenger Cars first used on or after 1 August 1992

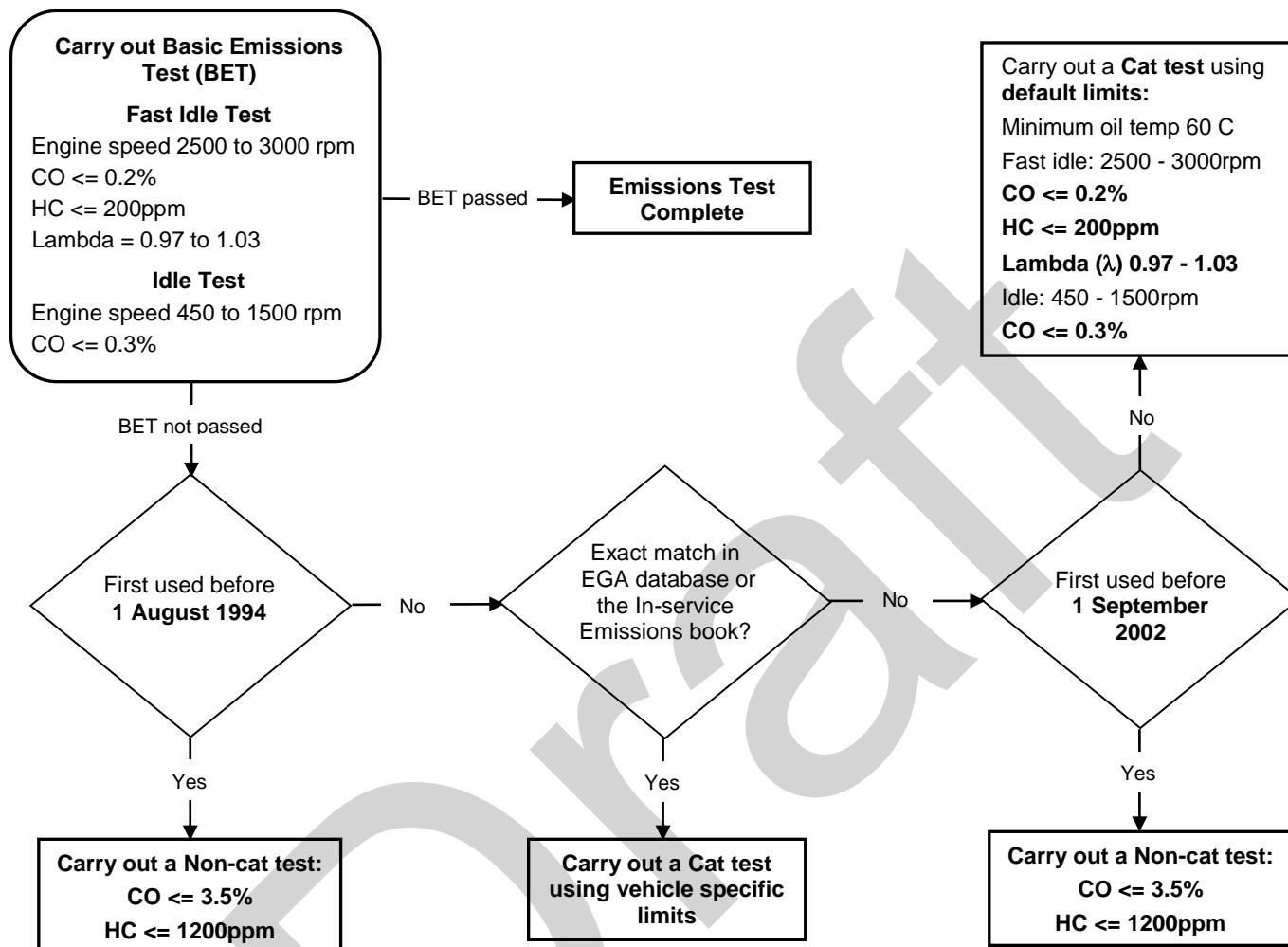

## Non-Catalyst Test

Where the flow charts indicate a non-cat test, determine the proportions of carbon monoxide (CO) and hydrocarbons (HC) in the exhaust gas over a period of at least 5 seconds at idle. Note that the HC test is not applicable to Compressed Natural Gas (CNG) fuelled vehicles.

The test should be conducted with the engine warm. Testing a cold engine could lead to an unjustified failure. It is important to ensure that any enrichment device (choke) is not operating.

The engine should be idling normally during the test and should not be subject to significant electrical loading such as heated seats or heated rear windows. If an engine will not idle, an assistant may apply light throttle pedal pressure.

To assess that these conditions are met, MOT Testers can either use their own judgement, or refer to manufacturers or other reliable data.

Any residual hydrocarbons (those indicated by the analyser when it is sampling only clean air) should be deducted from the HC reading obtained from the vehicle.

If a vehicle meets the CO requirement at its normal idling speed but fails the HC check, apply light pressure to the throttle and re-check the HC level at a high idle speed of 2000rpm. If the HC reading is then 1200ppm or less, the vehicle will meet both the CO and HC requirements.

# 8 Nuisance

## Basic Emissions Test

1. Ensure that a daily leak test has been carried out, before carrying out the inspection.
2. Ensure that the engine is hot, for example by checking the temperature gauge, the cooling fan has cut-in or the coolant hoses are hot. If the engine is not at normal temperature raise the engine speed to between 2000 and 3000rpm and maintain this speed until normal temperature has been reached.
3. Attach the engine speed measuring device or using the vehicle tachometer, ensure the engine is idling normally.
4. Perform a HC hang-up check and ensure that  $HC < 20ppm$  before continuing. Insert the analyser sample probe.
5. Carry out a fast idle test by raising the engine speed to a fast idle between 2500 and 3000rpm and hold steady. Note the readings for CO, HC and lambda, and record the results.
6. Allow the engine to return to idle. Note the CO reading and record the result.

To pass the Basic Emissions Test, the following requirements must be met:

Fast idle test (2500 - 3000rpm):  $CO \leq 0.2\%$ ;  $HC \leq 200ppm$ ; Lambda between 0.97 and 1.03.

Idle test (450 - 1500rpm):  $CO \leq 0.3\%$ .

**If the vehicle passes the Basic Emissions Test**, the analyser will produce two printouts. One must be retained by the VTS for three months and the other given to the vehicle presenter.

**If the Basic Emissions Test requirements are not met**, the analyser will prompt the user to enter the vehicle information before continuing to carry out either a full catalyst test or a non-catalyst test as appropriate. See also the flow charts within this section.

## Full Catalyst Test

**It is recommended that the extended test** is carried out as soon as possible after the BET Test. This allows the test to be carried out on a fully warmed up engine.

**Use the flow charts within this section** to establish which emissions test and limits must be applied to the vehicle under test. Where vehicle specific limits apply, these should be identified using MOT Testing Service or the EGA database.

**To find an exact match**, the vehicle make, model, model code, engine code, engine size and VIN may be required. If after normal cleaning and/or scraping to establish a particular code, it is still illegible or inaccessible, carry on as if no exact match was found and test to default limits.

However, for any vehicle which is an exact match for everything but the unestablished code, use the lesser of the default limits or vehicle specific limits.

Carry out the full catalyst test as follows:

1. Connect the engine speed and oil temperature measuring devices. Where engine speed can only be measured by the removal of a cosmetic engine cover, the speed measurement must still be carried out if the cover can be easily un-clipped. Where engine speed cannot be measured then the vehicle tachometer should be used if fitted. Otherwise engine speed measurement may be by-passed and a subjective estimate made.
2. Check the engine oil temperature. If it is below the minimum vehicle specific requirement, raise the engine speed to between 2000rpm and 3000rpm and maintain this speed until the minimum engine oil temperature has been reached. Remove temperature measuring probe and replace dipstick.
3. Engine oil temperature must be measured whenever possible, using the approved device. Where, in exceptional circumstances, the engine oil temperature cannot be measured, check that either:

# 8 Nuisance

- the temperature gauge indicated that the engine was at its normal operating temperature
  - the cooling fan had cut in
  - the coolant pipes were hot
4. Perform a HC hang-up check and ensure that HC<20ppm before continuing. Insert the analyser sample probe.
  5. If the engine speed is clearly above the vehicle specific limit and this can be easily adjusted, a tester may perform the adjustment and complete the test - the adjustment is not, however, part of the MOT test.
  6. Follow the EGA prompts until the full catalyst test is completed, at which point the analyser will produce two printouts.
  7. One copy of the printout must be retained by the VTS for three months and the second copy given to the vehicle presenter.

## Engine Malfunction Indicator Lamp

Turn on the ignition and check that the engine Malfunction Indicator Lamp (MIL) illuminates and then goes off.

Defect	Category
(a) Emissions levels exceed the manufacturer's specified limits.	Major
(b) Emissions levels exceed default limits.	Major
(c) Lambda coefficient outside the default limits or the range specified by the manufacturer.	Major
(d) Emissions test unable to be completed.	Major
(e) Engine is idling clearly above its normal idle speed.	Major
(f) Exhaust emits dense blue or clearly visible black smoke for a continuous period of 5 seconds at idle.	Major
(g) Exhaust emits excessive dense blue or clearly visible black smoke during acceleration which would obscure the view of other road users.	Major
(h) Engine MIL inoperative or indicating a malfunction.	Major

## 8.2.2 Compression ignition engine emissions

### 8.2.2.1 Exhaust emission control equipment

**This inspection is restricted to** components that are readily visible and identifiable, such as a diesel oxidation catalyst, diesel particulate filter, selective catalytic reduction valve etc.

**Diesel particulate filters (DPF)** should be checked for evidence that the DPF has been removed or otherwise tampered with. Where a DPF canister has clearly been cut open and re-welded, it should be rejected unless evidence can be provided that the canister was cut open for legitimate reasons, such as filter cleaning.

Defect	Category
(a) Emission control equipment fitted by the manufacturer missing, obviously modified or obviously defective.	Major
(b) An induction or exhaust leak that could affect emissions levels.	Major
(c) Evidence that the diesel particulate filter has been tampered with.	Major

# 8 Nuisance

## 8.2.2.2 Opacity

**This inspection does not apply to** tricycles, 'L' category vehicles or electric/combustion engine (Hybrid) vehicles.

**Pre-1980 vehicles** are only subject to a visual inspection of emitted smoke at both idle and during free acceleration.

**An approved diesel smoke meter (DSM)** will be needed to perform this inspection on vehicles first used on or after 1 January 1980.

**The probe on some types of smoke meter** must be correctly aligned with the exhaust gas flow. Reference to the smoke meter manufacturer's instructions may be necessary.

**Do not carry out a smoke test** if the engine is not in a safe condition to do so. It is important to establish it is safe by questioning the vehicle presenter and carrying out a brief examination of the engine. The smoke test should not be carried out if:

- there is insufficient oil in the engine
- the engine oil pressure is too low
- there is abnormal engine noise
- the governor has been tampered with
- the camshaft belt is in an unsatisfactory condition

If it is considered unsafe to conduct the smoke test, the reason for refusing to carry out the test must be clearly shown on the VT30 (see Introduction 4h).

**On pre-1980 vehicles** the engine should be at its normal operating temperature. This may be established by, for example, the temperature gauge, cooling fan cut in or hot coolant hoses.

**Post 1980 vehicles** are subject to an instrumented smoke test and it is important to ensure the engine is at least 80 °C or normal operating temperature if lower, before carrying out the test. This should be achieved by use of an engine oil temperature probe or other approved device.

Alternatively, if owing to vehicle configuration, or where this measurement is impractical, the establishment of the engine's normal operating temperature may be made by other means, for example by the operation of the engine cooling fan. It is not normally sufficient to run the engine with the vehicle stationary to warm it up to temperature.

**When testing vehicles fitted with automatic transmission** care must be taken to avoid overheating the transmission system. Do not carry out unnecessary engine acceleration or prolonged high revving of the engine. Reference to the vehicle manufacturer's instructions may be necessary.

**If a vehicle has a dual exhaust system**, then the smoke test must be repeated and the emissions from the tailpipes averaged. This is done by adding together the readings and dividing by two, for example:

1st pipe emits smoke level of 1.50m<sup>-1</sup>

2nd pipe emits smoke level of 1.00m<sup>-1</sup>

Average smoke level is:  $\frac{1.5 + 1.0}{2} = 0.75\text{m}^{-1}$

A dual exhaust system has two separate pipes from the engine manifold to the tailpipes. Even if there is a balance tube between the separate pipes it is still considered a dual exhaust.

**Maximum engine revs cannot be achieved** on some vehicles due to design features. Where this is the case, the vehicle must be tested as presented. Such vehicles, as well as some with low emission diesel engines (mainly Euro IV and onwards) may fail to trigger a reading on the DSM.

**Where no reading can be obtained** or the DSM shows an error, the printout should be marked accordingly showing that the emissions limits were tested and met but the DSM could not register the reading.



# 8 Nuisance

If the DSM will not produce a printout then the tester must make a written note of the following: -

- test station number
- testers name
- date and time
- test number
- vehicle type
- vehicle registration number
- that the vehicle passed the emissions test
- no print out was produced due to low emissions

**This information must be recorded** and kept with the emissions records for 3 months.

### Test Procedure (pre-1980 vehicles)

1. If the engine checks are satisfactory and having removed any oil temperature probe, raise the engine speed to around 2500rpm, or half the maximum engine speed if this is lower, and hold for 30 seconds to fully purge the inlet and exhaust system.
2. Allow the engine to return to idle and assess the smoke emitted from the tailpipe.
3. Rapidly increase the engine speed to 2500rpm or half maximum engine speed if this is lower and assess the smoke emitted from the tailpipe under acceleration.

### Test Procedure (post 1980 vehicles)

1. Before starting the test, ascertain the maximum smoke level limit for the vehicle and enter the required details into the diesel smoke meter. This will be:
  - a. for vehicles first used before 1 July 2008 not more than the level specified on the manufacture's plate, or where no value displayed:
    - for a non-turbocharged engine not more than  $2.5\text{m}^{-1}$
    - for a turbocharged engine not more than  $3.0\text{m}^{-1}$
  - b. for vehicles first used on or after 1 July 2008 not more than the level specified on the manufacture's plate, or  $1.5\text{m}^{-1}$  where no value displayed
  - c. for vehicles first used on or after 1 January 2014 not more than the level specified on the manufacture's plate, or  $0.7\text{m}^{-1}$  where no value displayed.
2. If the engine checks are satisfactory and having removed any oil temperature probe, raise the engine speed to around 2500rpm, or half the maximum engine speed if this is lower, and hold for 30 seconds to fully purge the inlet and exhaust system.
3. Raise engine speed slowly to maximum to check the operation of the governor. Once the engine speed has stabilised or if it becomes clear that the governor is not working, release the pedal, return to idle and stop the engine.
4. Prompt the meter to carry out a zero check and then insert the probe fully and securely in line with the gas flow. Restart the engine.
5. Following the meter prompts, depress the accelerator pedal quickly and continuously but not violently, to reach full fuel position **in less than one second**. Hold it there until a release prompt is given, then immediately release the pedal. Allow the engine, and any turbocharger fitted, to return to idle speed.

**After the first acceleration** read the smoke level displayed on the meter. If it is equal to, or less than the limit for the vehicle, the vehicle has passed the opacity test and a pass result will be displayed on the meter.

# 8 Nuisance

If the first acceleration smoke level is greater than the limit for the vehicle, carry out two further accelerations following the meter prompts. At the end of the third acceleration, read the mean smoke level displayed on the meter. If it is at or below the appropriate limit, the vehicle has passed this part of the test.

If the mean smoke level is still too high, carry out further accelerations up to a maximum of six in total.

After each acceleration, check the mean reading. This part of the test is complete when either the mean of any three consecutive smoke readings is at or below the appropriate limit, or six accelerations have been performed.

In cases where smoke levels are significantly in excess of the specified limit values after one acceleration, testers may choose to abort the emissions test to avoid unnecessary testing.

On vehicles fitted with a diesel particulate filter, also check that no visible smoke is emitted from the exhaust during the metered check.

## Engine Malfunction Indicator Lamp

Turn on the ignition and check that the engine Malfunction Indicator Lamp (MIL) illuminates and then goes off.

Defect	Category
(a) Smoke opacity levels exceed the manufacturer's specified limit.	Major
(b) Smoke opacity levels exceed default limit.	Major
(c) Exhaust emits excessive smoke or vapour of any colour to an extent likely to obscure the vision of other road users.	Dangerous
(d) Exhaust on a vehicle fitted with a diesel particulate filter emits visible smoke of any colour.	Major
(e) Emissions test unable to be completed.	Major
(f) Emissions test aborted because smoke levels are significantly in excess of the specified limit values.	Major
(g) Engine MIL inoperative or indicating a malfunction.	Major

### 8.3 Not in use

### 8.4 Other Environmental Items

#### 8.4.1 Fluid leaks

This inspection applies to all vehicles and should be carried out with the engine idling. Fluids such as engine coolant, screen wash and fluid required for Selective Catalyst Reduction are not included.

Leaks from batteries, braking, steering, suspension and fuel systems are covered elsewhere in this Manual.

Fluid leaks should only be considered excessive if they deposit greater than a 75mm diameter pool in 5 minutes, or if there are a number of leaks which collectively deposit fluid at the same rate.

Excessive fluid leaks may also constitute a reason for refusing to carry out the test (see Introduction item 4).

# 8 Nuisance

Defect	Category
(a) Fluid:	
(i) leaking excessively and likely to harm the environment or to pose a safety risk to other road users	Major
(ii) leaking continuously and likely to pose a serious risk to road safety.	Dangerous

Draft

# 9 Supplementary Tests for Buses and Coaches

---

## Section 9 - Contents

- 9.1 Doors**
  - 9.1.1 Entrance and exit doors
  - 9.1.2 Emergency exits
- 9.2 Not in use**
- 9.3 Not in use**
- 9.4 Not in use**
- 9.5 Not in use**
- 9.6 Passenger Grab Handles**
- 9.7 Steps and Stairs**

Draft

# 9 Supplementary Tests for Buses and Coaches

## 9.1 Doors

### 9.1.1 Entrance and exit doors

**A door should only be rejected** for deteriorated condition if its function is impaired or it is likely to cause injury.

**Emergency controls** are only required on power operated doors except those constructed or adapted for the secure transport of prisoners.

**If it is not known whether a 'door open' warning device is fitted**, the benefit of the doubt must be given.

Defect	Category
(a) An entrance or exit door defective in operation.	Major
(b) An entrance or exit door: <ul style="list-style-type: none"> <li>(i) excessively deteriorated</li> <li>(ii) deteriorated and likely to cause injury.</li> </ul>	Minor Major
(c) An entrance or exit door emergency control inoperative.	Major
(d) An entrance or exit door remote control or warning device inoperative.	Major

### 9.1.2 Emergency exits

**This inspection applies to** all buses first used on or after 1 April 1988 except those constructed or adapted for the secure transport of prisoners.

**Vehicles first used on or after 1 April 1988** must have at least one passenger door on the nearside and either:

- an additional passenger door at the rear
- an emergency exit at the rear
- an emergency exit on the offside (not the driver's door).

Where there is an additional passenger door at the rear, there is no requirement for the vehicle to have a designated emergency exit.

**All designated emergency exits**, whether doors, windows or hatches must be clearly marked (letters should be at least 25mm high) on both the inside and outside; "EMERGENCY DOOR", "FOR EMERGENCY USE ONLY", "IN EMERGENCY" or similar words.

**Where a 'break glass' emergency exit is fitted** a suitable hammer or similar device must also be present. Emergency exits must latch securely closed and be able to be opened from both inside and outside the vehicle (with the door unlocked).

Defect	Category
(a) An emergency exit defective in operation.	Major
(b) An emergency exit sign: <ul style="list-style-type: none"> <li>(i) illegible or not in accordance with the requirements</li> <li>(ii) missing.</li> </ul>	Minor Major
(c) Missing break glass hammer (where required).	Minor
(d) No emergency exit provided (where one is required) or access blocked.	Major

# 9 Supplementary Tests for Buses and Coaches

9.2 Not in use

9.3 Not in use

9.4 Not in use

9.5 Not in use

## 9.6 Passenger grab handles

**Rails and grab handles** should be rejected if they are insecure or in a condition likely to cause injury. This includes those that form part of seat back.

Defect	Category
(a) Not in use.	
(b) A passenger grab handle:	
(i) defective	Minor
(ii) insecure or unusable.	Major

## 9.7 Steps and stairs

**This inspection applies to** all passenger entrance/exit steps.

**The inspection of stairs** applies only to double deck or split level vehicles. They should be rejected if they are in a condition likely to be a trip hazard or cause injury.

Defect	Category
(a) A step or stair:	
(i) in a deteriorated condition	Minor
(ii) significantly damaged	Major
(iii) in such a condition as to affect the stability of passengers during use.	Dangerous
(b) A retractable step not operating correctly.	Major

# 10 Seat Belt Installation Check

## 10.1 Seat belt installation guidance notes

**All belts should be checked for installation**, operation and wear, except the following categories which shall be checked for operation and wear only:

1. Seat belts provided for rear or side facing seats.
2. Disabled person's belts which are permanently attached to the vehicle.
3. Child restraints which are permanently attached to the vehicle.
4. Obligatory seat belts as specified on pages 3 to 10 of Section 5.1.

**No check is required for disabled person's belts** or child restraints which are not permanently attached to the vehicle.

**It will be necessary to ask the operator to remove seat cushions** and to open any access flap or luggage locker door, which was designed to be capable of being readily opened, to allow as much as possible of the seat belt installation to be seen.

**Some parts of the installation** may only be visible with the vehicle on a pit or hoist.

**If an operator has been provided with documentary evidence** to show that a seat belt complies with type approval standards (but has not been fully type approved) or that is traceable to an installation tested and shown to meet the requirements of ECE Regulation 14 or Community Directive 76/115 it should be produced at the time of test.

It should show registration number or chassis number of the vehicle and the name and address of the installer. It should also show the test number and the date and location of the test of the installation.

Original certificates are required. Photocopies are not acceptable. Presentation of the certificate would not replace the need for the examination to be conducted but it may support the quality of the installation and help resolve differences over the acceptability of the installation, for example reinforcement plates used.

**Diagram 1 on page 5** of this section shows typical methods of attaching seat belts. Where the word 'close' is used it should generally be regarded as 50mm or less.

- A. Check that on all belts the buckle operates correctly and the seat belt adjusts satisfactorily. Subsequent cutting or reworking of the webbing will be a reason for failure.  
It is acceptable for the free end of looped belts or static belts to be reworked to the extent of folding and stitching the webbing so that it cannot pass back through the buckle to prevent the buckle from being dismantled. Any knots in the belt webbing are unacceptable.
- B. Seat squabs should be removed to aid the inspection of the condition of the belt and mountings and replaced before the end of the test to allow inspection of the complete belt installation.
- C. Check for the presence of any sharp edges that the belt could rub on or pull across during use.
- D. Where seat belts, other than looped belts, are anchored to the seat frame or the vehicle floor they must be secured with mounting bolts in accordance with the following:

### Minimum Acceptable Size and Grade of Bolts for Seat Belt Anchorage's

Type of Anchorage	Minibus	Coach or Large Bus
Single Anchorage	M10 Standard Material	M8 High Tensile Steel M10 Standard Material
Double Anchorage	7/16" Standard Material M10 High Tensile Steel	7/16" Standard Material M10 High Tensile Steel

# 10 Seat Belt Installation Check

- E. The grade of the bolt may be identified by markings on the bolt head:
- standard material = P, 4.6 or SAE equivalent
  - high tensile steel = S, 8.8 or SAE equivalent
  - no markings = standard material

If the examiner cannot determine the grade of bolt it must be assumed to be of Standard Grade.

It is paramount that the appropriated sized bolt is used in the seat belt anchorage, for example an 8mm bolt should not be used in an 11.5mm diameter hole. The only exception to this is where there is a “stepped washer” or collar used to eliminate the excessive clearance and a suitable washer is fitted between the bolt head and the anchorage to prevent the bolt pulling through.

The use of smaller bolts, self-tapping screws or wood screws is not acceptable.

- F. It is not acceptable to drill tubular seat frames to allow belts to be bolted to the frame except in cases where a manufacturer has approved the installation and the operator presents a certificate issued by the manufacturer or their agent declaring that the installation is satisfactory.
- G. Clamp type brackets are acceptable provided they are properly secured.
- H. On seats constructed with a wooden frame it is unacceptable to mount the belts either directly to the frame or to a metal base which is attached to the frame only by wood screws. Unless there are additional reinforcement brackets fitted that provide a direct load path to the seat and leg and side mounting, the installation would be rejected.
- This reinforcement could take the form of steel angle sections or plates, alternative materials may be used provided they are of comparable strength (see Diagrams 3 and 4 for details of a typical installation).
- I. Where seat belts are attached to thin sheet metal frames the bolts anchoring the belt must be of the minimum dimensions shown in note D and must be adequately supported by the use of load spreading washers between the frame and the nut.
- Typically this would be 25mm in diameter and 2mm thick. If two belts are attached at the same point with a single bolt then a larger reinforcement plate 35mm diameter x 3mm thick (or a rectangular plate of minimum dimensions 21x46x3mm) must be used. The sizes quoted are for steel reinforcement plates, alternative materials may be used but must provide comparable strength.
- J. Where seat belts are fitted in the rear seats of a vehicle check the anchorage to ensure that it is not anchored solely to the thin metal sheet which separates the boot area from the passenger compartment. It is essential that seat belt anchorages be secured to a strong cross member connected to the structural members of the vehicle.

The connection should be to such a standard that there is confidence that it will be able to transfer the seat belt loads into the structure of the vehicle. This may involve the fabrication of an additional framework at the rear of the vehicle.

An example of typical reinforcement of this area would be by the use of additional square section tubing 40x40x3mm, or angle plate 50x50x4mm across the full width of the vehicle.

The sizes quoted are for steel reinforcement; alternative materials may be used but must provide comparable strength. A full width reinforcement that is only attached to the thin metal sheet is unacceptable and would be a reason for failure.

- K. Where seat belts are attached to thin sheet metal frames the bolts anchoring the belt must be of the minimum dimensions shown in note D and must be adequately supported by the use of load spreading washers between the frame and the nut.



# 10 Seat Belt Installation Check

Typically this would be 25mm in diameter and 2mm thick. If two belts are attached at the same point with a single bolt then a larger reinforcement plate 35mm diameter x 3mm thick (or a rectangular plate of minimum dimensions 21x46x3mm) must be used. The sizes quoted are for steel reinforcement plates, alternative materials may be used but must provide comparable strength.

- L. Where seat belts are fitted in the rear seats of a vehicle check the anchorage to ensure that it is not anchored solely to the thin metal sheet which separates the boot area from the passenger compartment. It is essential that seat belt anchorages be secured to a strong cross member connected to the structural members of the vehicle.

The connection should be to such a standard that there is confidence that it will be able to transfer the seat belt loads into the structure of the vehicle. This may involve the fabrication of an additional framework at the rear of the vehicle.

An example of typical reinforcement of this area would be by the use of additional square section tubing 40x40x3mm, or angle plate 50x50x4mm across the full width of the vehicle.

The sizes quoted are for steel reinforcement; alternative materials may be used but must provide comparable strength. A full width reinforcement that is only attached to the thin metal sheet is unacceptable and would be a reason for failure.

- M. Three point belts will only be accepted under the following circumstances:
- where the seat utilises tubular frames or tubular “H” pattern legs:
    - the seats have been reinforced as detailed in note K, or a purpose built structure to which belts are attached is fitted to the vehicle (an example is shown in diagram 5), alternatively the belts may be attached to solid bodywork
  - if purpose made seats designed with integral three point belts as standard have been fitted.
- N. Where seats that are permanently mounted in the vehicle have been fitted with lap belts or 3 point belts integral to the seat, then, if the seat utilises tubular frames or tubular “H” pattern legs it must be reinforced.

This will include welding metal buttresses, of similar thickness material as the foot, between the foot and the leg (see diagram 6). Also the welding of a diagonal brace, either in compression or tension, between the foot and the seat base attachment of each leg.

Alternatively documentary evidence of compliance with Directive 76/115 or ECE Regulation 14 can be presented.

On quick release seats where the feet are mounted directly to tracking by a coupling it may not be practical to weld a buttress to the leg or a diagonal brace to the foot due to the presence of the coupling (see diagram 7).

The coupling would prevent any reinforcement being placed in an effective position; also the coupling could be damaged if welding occurred close to it. On this type of installation the belts can be attached directly to the tracking with quick release mounts or the legs should be modified to use an alternative method of attachment to the tracking.

On seats where the feet are mounted to a metal bar or tube which is then connected to tracking by a quick release coupling, then the seat has to be reinforced with buttresses and diagonal brace as detailed above.

On vehicles with floor mounted seat belts where the belt is anchored close to the seat mounting bolt then the rear foot of each leg must be buttressed to the leg.

# 10 Seat Belt Installation Check

- O. If lap belts are fitted and there is the possibility of passengers hitting their heads on any harsh object such as a grab rail or seat stanchion, padding or other suitable protection must be provided on these objects.

The protection does not need to cover the full length of a seat grab rail but should cover a length of at least 300mm directly in front of each passenger.

Padding must be compressible, of a depth of at least 50mm measured to the surface of the bar and not compress more than 25mm under reasonable thumb pressure; or 25mm thick, and not compress more than 5mm. Ordinary seat foam or pipe lagging is unlikely to be of sufficient density for this purpose.

- P. Where belts are attached directly to a metal floor, a load spreading washer must be used between the nut and the floor.

The bolts must be of the sizes specified in note D. Typically this would be 25mm in diameter and 2mm thick. If two belts are attached at the same point with a single bolt then a larger reinforcement plate of minimum dimensions 35mm diameter and 3mm thick (or a rectangular plate of minimum dimensions 21x46x3mm) must be used.

The sizes quoted are for steel reinforcement plates; alternative materials may be used but must provide comparable strength.

Reinforcement plates should follow, as far as practicable, any contours in the floor to which they are attached.

- Q. Where a belt is attached directly to a wooden floor each anchorage must be reinforced with a plate of minimum dimensions 35mm diameter x 3mm thick (or a rectangular plate of minimum dimensions 21x46x3mm).

If two belts are attached at the same point with a single bolt then the reinforcement plate must have minimum dimensions of 92mm diameter x 3mm thick (or a rectangular plate of minimum dimensions 65x100x3mm).

If two belts are attached in close proximity to each other, then a single reinforcement plate of minimum dimensions 92mm diameter x 3mm thick (or a rectangular plate of minimum dimensions 65x100x3mm) should be used ensuring that the bolt holes are not too close to the plate edge.

Alternatively two steel reinforcement plates may be used but they must be of minimum dimensions 52mm diameter x 3mm thick (or a rectangular plate of minimum dimensions 46x46x3mm).

The sizes quoted are for steel reinforcement plates; alternative materials may be used but must provide comparable strength. Reinforcement plates should follow, as far as practicable, any contours in the floor to which they are attached.

- R. Lower anchorages should be at least 320mm apart. This need not be the distance between the anchorage points of the belt but it can be between two structural parts of the seat that the belt is routed round.

If the measurement is between mounting bolts it should be measured between bolt centres.

Check that the belt will not raise or significantly compress the seat cushion when subjected to a load. There will always be a small amount of compression which is acceptable.

Where mounting rails designed for the adjustment of seat pitch are fitted and utilise an angled claw type clamp (see Diagram 8) with a clamping face of less than 15mm wide it is not acceptable for a seat on which a belt is mounted to be merely clamped to the rail.

The clamp to the rear foot of each leg must be modified by fitting a bolt through each claw fitting. The bolt must clamp the rear foot of each leg to the rail, floor and a suitable structural member (as in most vehicles).

# 10 Seat Belt Installation Check

The bolts must have appropriately sized load spreading washers fitted beneath the bolt head and underneath the retaining nut. A single bolt should be not less than 8mm (5/16") diameter. Any alternative to this is only acceptable if documentary evidence is provided.

S. Parallel type claw fittings, for a seat on which a belt is mounted, will be considered satisfactory provided that the securing bolts are fully tightened (see Diagram 9).

T. If a seat, on which a belt is mounted, is bolted to a flat rail the bolts must pass through the leg, rail, floor and a suitable structural member.

It is acceptable for seats to be attached to a purpose built tracking (see diagram 2) designed for securing seats and wheel chairs, providing the tracking is securely attached to the vehicle structure with bolts or fasteners in all the retaining holes or marks provided by the manufacturers.

It is unacceptable to fit seats, with seat belts, directly to unsupported wooden floors unless additional reinforcement is provided.

This will involve the fitting of steel reinforcement plates of minimum dimensions 92mm diameter x 3mm thick (or a rectangular plate of minimum dimensions 65x100x3mm), between the under side of the floor and the securing nut below the floor of the rear leg and between the leg and the top side of the floor of the front leg.

If the area of the foot of the front leg is greater than 65x100mm, then the front reinforcement plate is unnecessary.

U. A "looped" type seat belt fitting is acceptable provided it is not free to float along any part of the seat structure. Any free movement in excess of 25mm is a reason for failure.

V. The upper anchorage point should be at least 475mm above the height of an uncompressed seat cushion. This dimension is to be measured parallel to the backrest.

The upper anchorage point should be a minimum of 110mm from the centre line of the seat back to the side of the seat.

W. A lap belt or the lap section of a 3 point belt must be positioned to lie across the wearer's pelvis and not the stomach. This is to reduce the risk of abdominal injury and to prevent "submarining". In practise this may result in the belt lying across the top quarter of the thigh.

Seat belt components should not be fitted to seats in such a way that they significantly intrude into the gangway space and are likely to cause injury to passengers by either tripping or by hitting the component.

# 10 Seat Belt Installation Check

## 10.2 Seat belt installation diagrams

**Diagram 1: Typical Methods of Attaching Seat Belts**

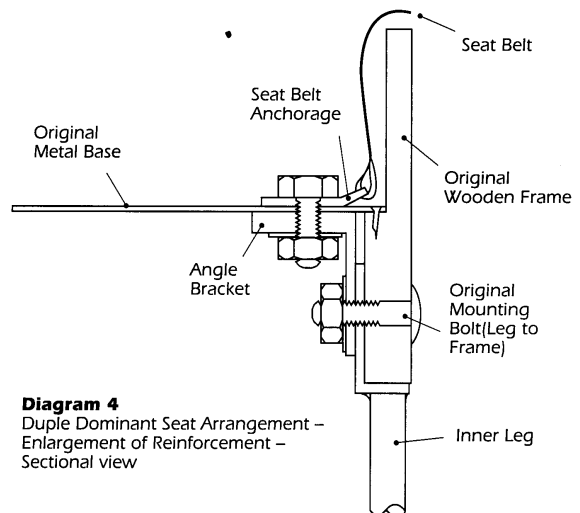
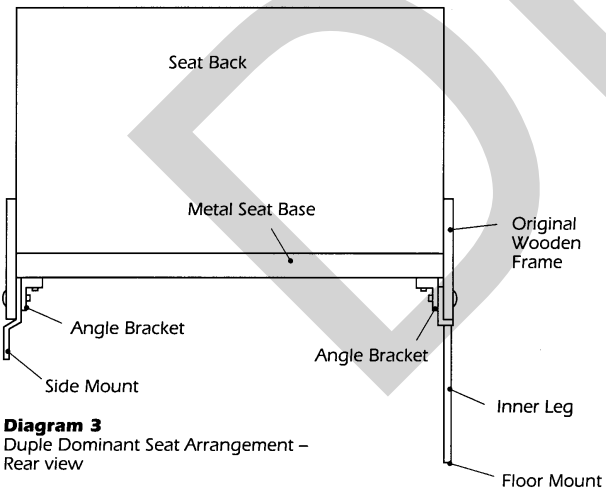
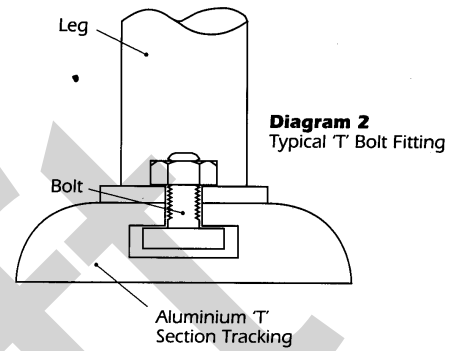
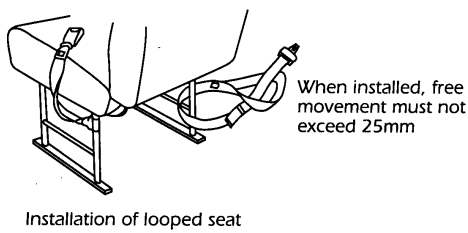
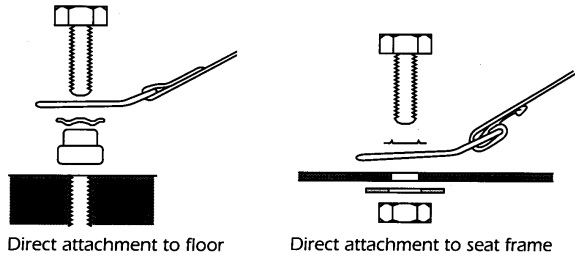

# 10 Seat Belt Installation Check

Diagram 5

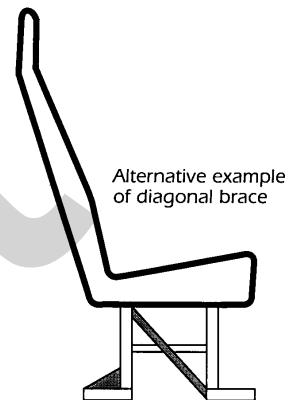
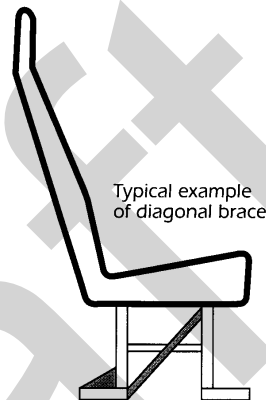
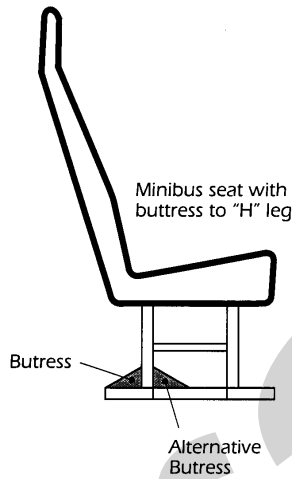
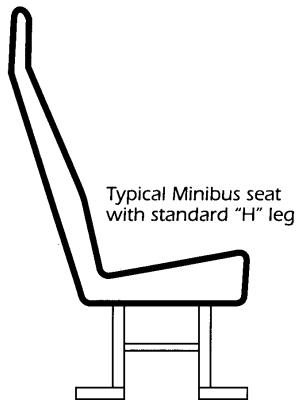
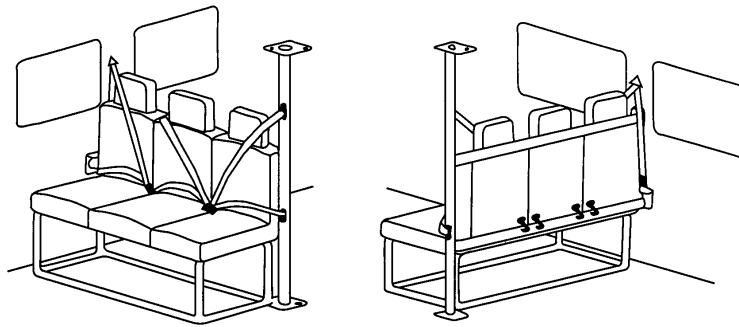
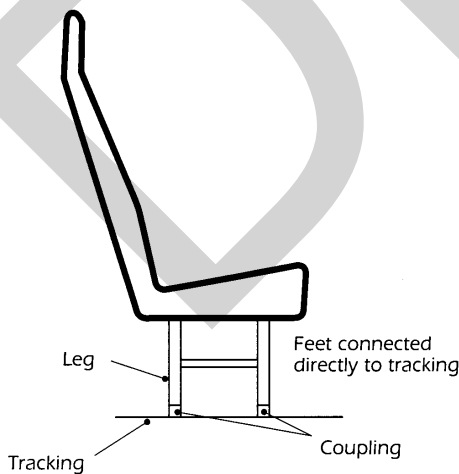
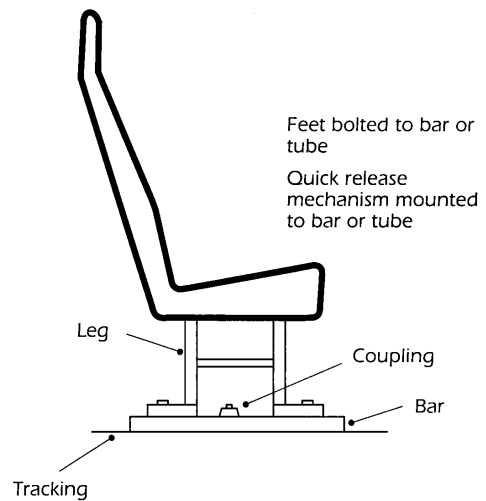

Diagram 6



Example of quick release seats that may not be suitable for reinforcement



Example of quick release seat that is suitable for reinforcement

Diagram 7

# 10 Seat Belt Installation Check

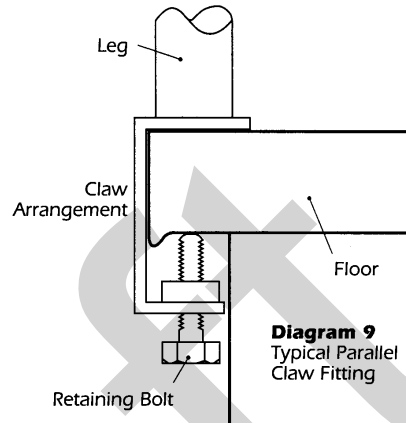
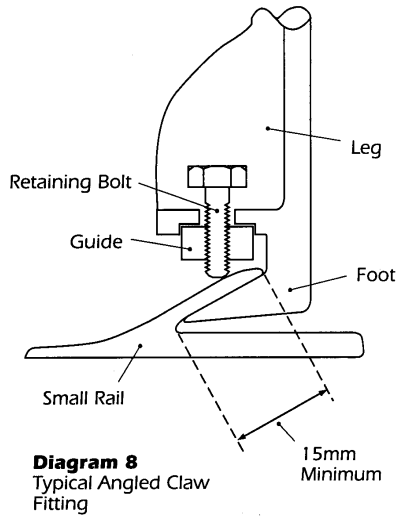

# 10 Seat Belt Installation Check

Defect	Category
a. Evidence that original webbing has been cut and/or reworked; eg belts knotted, fraying or fluffing removed/ sealed by burning etc (see note A)	Major
b. any part of the installation which has a sharp edge which could or is likely to cut or abrade the webbing	Major
c. a directly attached anchorage not secured by standard seat belt mounting bolts and washers as detailed in note D	Major
d. an anchorage insecure	Major
e. a tubular seat frame that has been drilled for the purpose of attaching a seat belt (see note E)	Major
f. a directly attached anchorage not attached to a load bearing member or without suitable reinforcement (see notes I, N and O)	Major
g. retro-fitted three point belt which is not mounted on a suitable structure (see diagram 5)	Major
h. tubular frame legs or tubular "H" pattern legs which have not been reinforced with buttressing and diagonal bracing (see diagram 6), or buttressing where a floor mounted belt is fitted close to a seat leg	Major
i. retro-fitted three point belt fitted to a seat on which the leg and frame has not been suitably modified (see note J)	Major
j. rail or other harsh object without suitable padding as required at note L	Major
k. lower anchorage's less than 320mm apart (see note M)	Major
l. in such a position that loading the belt causes the cushion to be raised or significantly compressed thus allowing the occupant effectively to move forward	Major
m. an anchorage attached to the floor without reinforcement plates of a suitable size and contour (see notes N and O)	Major
n. with load spreading washer(s) missing from anchorage bolt (see note H)	Major
o. claw type seat mounting with inadequate means of securing claw (see note Q)	Major
p. on a seat fitted to a flat rail the bolt does not pass through the leg, rail, floor, and a suitable structural member, or the floor has not been suitably reinforced	Major
q. tracking for seats and wheelchairs insecure (see note S)	Major
r. free movement for a looped belt more than 25mm at the anchorage	Major
s. upper anchorage of three point belt less than 475mm above uncompressed seat cushion measured parallel to the seat back (see note V)	Major
t. upper anchorage of three point belt(s) less than 110mm from centre line of seat (see note V)	Major
u. incorrect positioning of a lap belt or lap section of a three point belt, ie the belt lies across the stomach or forward of the top quarter of the thigh	Major
v. a seat belt component fitted to a seat significantly intrudes into a gangway and is likely to cause injury to a passenger.	Major

## Appendix A – Structural Integrity and Corrosion

---

### Contents

1. Introduction
2. Prescribed Areas
3. Corrosion Assessment
4. Failure Criteria Within 'Prescribed Areas'
5. Failure Criteria Not Within 'Prescribed Areas'
6. Highly Stressed Components
7. Thin Gauge Steel Pressings
8. Vehicles With Separate Bodies
9. General Guidance
10. Acceptable Methods of Repair
11. Unacceptable Methods of Repair
12. Testable Items Mounted to Plastic Structures
13. Repairs to Non-Metallic Load-Bearing Structures
14. Panel Removal or Replacement with Different Materials
15. Diagrams to Show Main Load Bearing Areas



## Appendix A – Structural Integrity and Corrosion

---

### 1. Introduction

The effect of corrosion on the safety of a vehicle depends on its extent and the function of the section or component on which the corrosion has occurred.

A relatively small amount of corrosion in an important part of a vehicle structure, where it compromises its load bearing capacity, can make a vehicle unsafe. On the other hand, excessive corrosion on non-structural sections may have little or no effect on the vehicle's safety.

Corrosion of a particular part, such as a door sill, may be very important on one type of vehicle construction, but less important on another. This is highlighted in Diagrams 1 to 4 at the end of this Appendix, where the shaded portions indicate the important load bearing parts of various typical vehicle constructions.

### 2. Prescribed areas

Certain areas of the vehicle structure are particularly important for the safety of a vehicle and particular attention must be paid to these areas during an inspection. These areas are:

- the load bearing parts of the vehicle to which the testable items defined in Sections 1, 2, 5 and 7 of the Inspection Manual are mounted
- any load bearing or supporting structure or supporting panelling within 30cm of the mounting location

To give an example; when examining a seat belt mounting on an inner sill, consideration must be given to the outer sill (or the sill reinforcement if the outer sill is a plastic cover), door pillar, floor panel or any other structural part within 30cm of the component's mounting point. It is accepted that it is not always possible to assess some of these areas due to the fitment of body trim etc.

### 3. Corrosion assessment

Having identified the important load bearing members and 'prescribed areas' on a vehicle, the tester should determine whether they are excessively corroded, firstly by visual inspection and then by finger and thumb pressure.

If necessary, the Corrosion Assessment Tool should be used to assess the extent of any corrosion by careful scraping or light tapping of the affected areas.

It is important that use of the Corrosion Assessment Tool is restricted to ascertaining that the failure criteria are met and not used for heavy scraping or poking of the affected areas.

Excessively corroded metal, or metal treated with filler, emits a duller sound than unaffected metal. It is not permissible to apply heavy impact blows or to use a sharp instrument to probe at the structure.

### 4. Failure criteria within 'prescribed areas'

Corrosion within a 'prescribed area' should be rejected if:

- the corrosion has caused a hole in the metal, or
- it is weakened to the extent that by finger and thumb pressure it does not feel sound, or
- finger and thumb pressure or use of the Corrosion Assessment Tool causes a hole.

Additionally, any fracture or inadequate repair (see items 11 to 14) within a 'prescribed area' should also be rejected. However, deliberate modification or severe distortion within a 'prescribed area' should only be rejected if the strength of a component mounting, load bearing member, supporting structure or supporting panelling is significantly reduced.

## Appendix A – Structural Integrity and Corrosion

---

### 5. Failure criteria not within prescribed areas

Structural fractures, deformation or corrosion not within the 'prescribed areas' are dealt with in Section 6 of this Manual. Such defects in these areas should only lead to refusal where the defect adversely affects braking or steering due to structural misalignment, or by severely reducing the strength or continuity of a main load bearing structural member.

Diagrams 1 to 4 of this Appendix show the main load bearing members of various types of vehicle construction which need to be considered.

### 6. Highly stressed components

The severity of general or local corrosion in highly stressed components, such as steering and suspension arms, rods, levers etc. can be assessed by lightly tapping or scraping with the Corrosion Assessment Tool.

In places inaccessible to the Corrosion Assessment Tool, an alternative blunt instrument may be used. A highly stressed component should be rejected if corrosion has resulted in serious reduction in the overall thickness of the material, or has caused a hole or split.

Welded repairs to highly stressed components such as steering/suspension arms, rods, levers etc are not normally acceptable, other than where the component is made up of sections that are welded together. In these cases the repair should appear to be as strong as the original design.

### 7. Thin gauge steel pressings

It is common to use thin gauge pressings for certain steering and suspension components, mountings, sub-frames and cross members.

These are designed to have minimal material usage with maximum strength, resulting in hollow or open sections or 'up facing' areas in which road dirt impregnated with salt or other chemicals collects causing serious but often very localised corrosion.

These types of components require extra vigilance as there may be little evidence of corrosion on initial inspection, but may reveal severe material failure when looked at more closely.

### 8. Vehicles with separate bodies

Some vehicle types have bodies and various mechanical components attached to a separate under frame. The frame is the main load bearing structure with a passenger cell and possibly a separate load bed secured on top of the frame, which may also be load bearing or supportive.

Excessive corrosion within these body panels should only be rejected if the failure criteria are met for either:

- prescribed areas
- body security
- it is likely to adversely affect the correct functioning of the braking or steering.

### 9. General guidance

The presenter should be advised of any corrosion or deformation which has not yet reached the stage where it meets the criteria for rejection. However, it may be necessary to refuse to test the vehicle if excessive deformation or corrosion could result in injury or further damage to the vehicle and/or testing facility.

### 10. Acceptable methods of repair

It is essential that repairs to structural components are properly carried out and appear to be as strong as the original structure. This requires that suitable materials of appropriate gauge or thickness are used and any plating or welding extends to a sound part of a load bearing member.

## Appendix A – Structural Integrity and Corrosion

---

Where a load bearing panel was originally spot welded, it is acceptable for a replacement panel or patch repair to be spot welded along that flange, provided that the original panel or section has been removed.

Stitch or plug welding is an acceptable alternative to spot welding. In all other circumstances, patch repairs must be continuously seam welded.

Some vehicle manufacturers have recommended repair methods that use MIG brazing, a combination of adhesive bonding and riveting, or amalgamations of these with other joining methods. Such repairs must therefore be accepted unless they are clearly inadequate.

### 11. Unacceptable methods of repair

Gas brazing, soldering, adhesive bonding, fibre reinforcement and body filler are bonding processes and are not regarded as strong enough for repairs to load bearing members although they are normally adequate for other repair work.

It is accepted that it is sometimes difficult to identify the repair method, especially after the repair has been covered in paint or underseal. If the method of repair is in doubt the tester should pass and advise.

### 12. Testable items mounted to plastic structures

Testable items, such as steering racks, sub frames and seat belts, are sometimes mounted directly to plastic structures that do not have metal reinforcement.

Non-metallic structures must be assessed on their merits. Evidence of weakness such as cracks, separation or delamination within a 'prescribed area' or a component flexing on its mounting to the extent that it is clear that it is likely to work loose or break away should be rejected.

### 13. Repairs to non-metallic load-bearing structures

Repairs to non-metallic structures are not acceptable within prescribed areas. Any repairs outside of these areas should be as strong as the original structure.

### 14. Panel removal or replacement with different materials

On a vehicle of integral construction the strength and stiffness of the whole structure may be seriously affected by any panel being removed or replaced by a panel of different material.

If it is considered that a modification has significantly reduced the original strength and stiffness of the structure within a prescribed area, the tester should fail the vehicle under the appropriate section. If there is doubt about the effect of the modification the tester should pass and advise.

It is unacceptable for plastics to replace or reinforce corroded or weak metal in prescribed areas and load bearing sections.

## Appendix A – Structural Integrity and Corrosion

### 15. Diagrams to Show Main Load Bearing Areas

Diagram 1

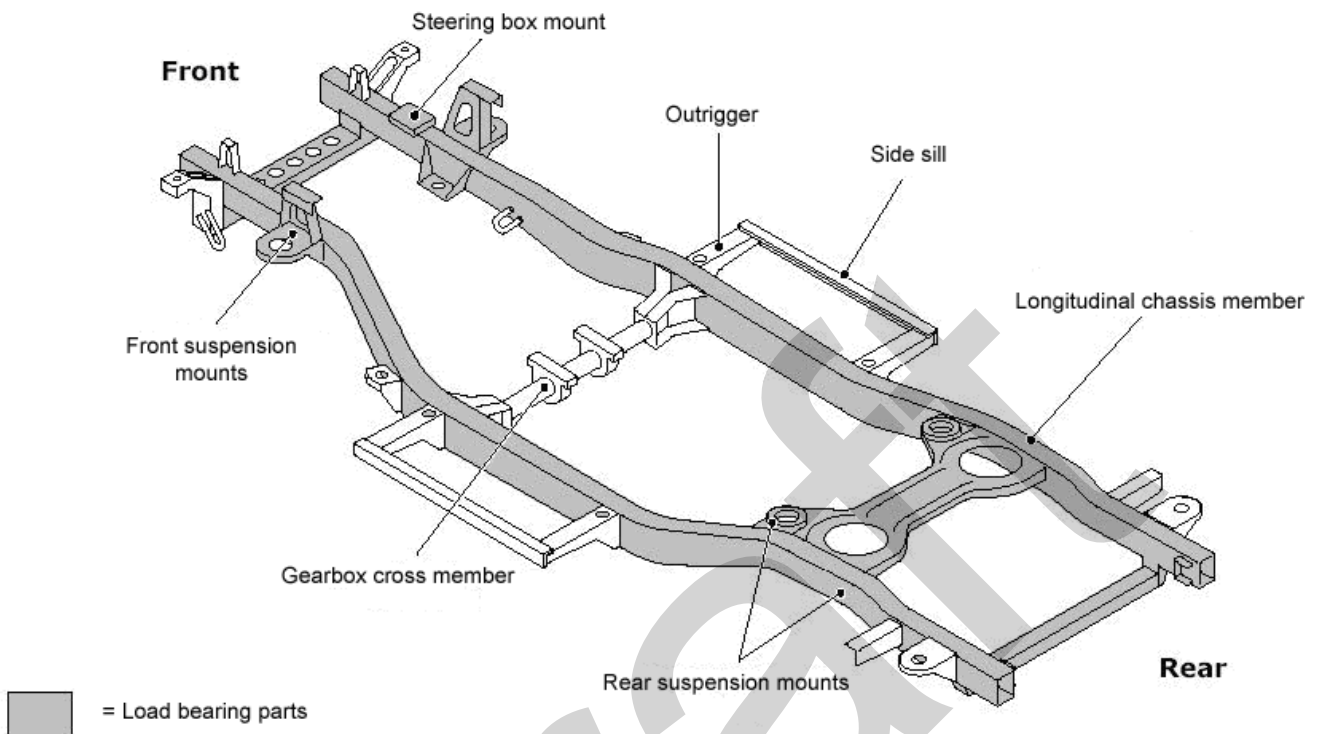
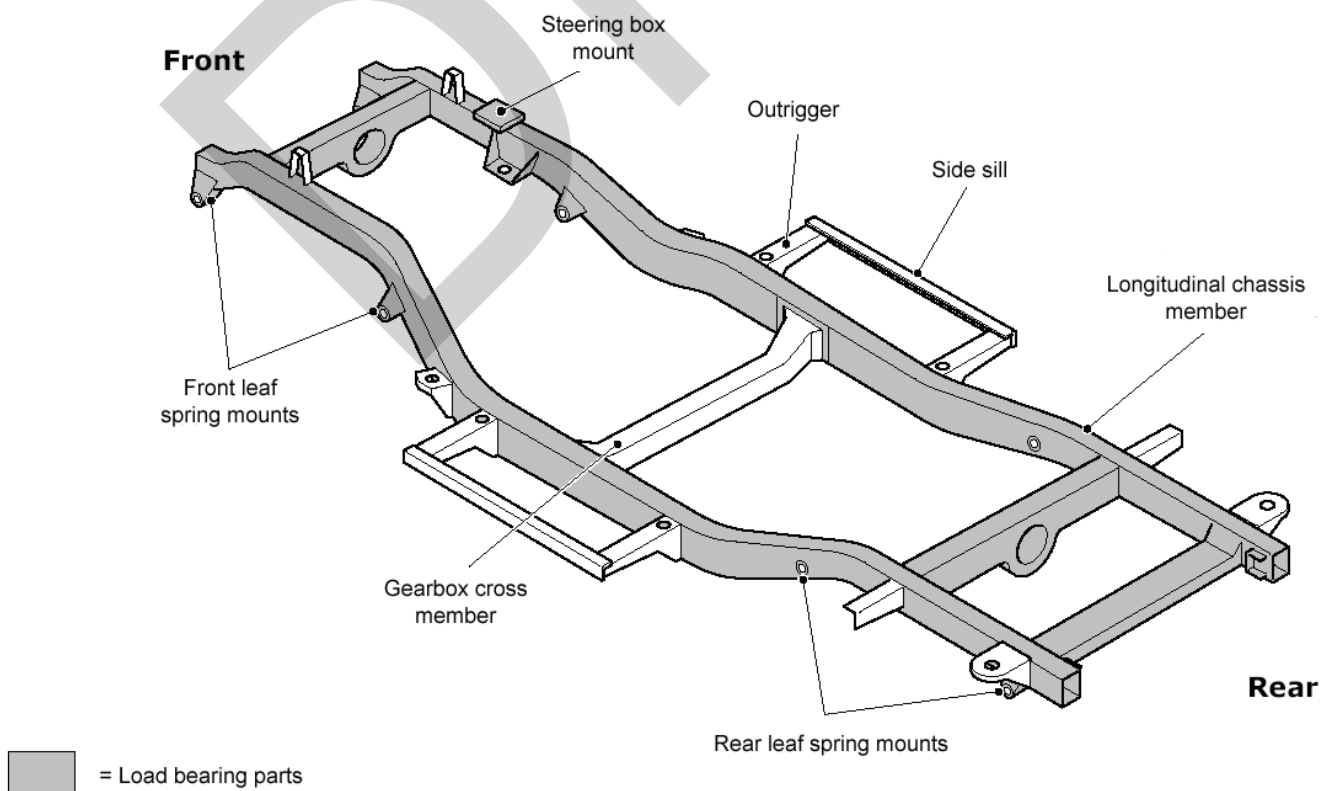

Diagram 2



# Appendix A – Structural Integrity and Corrosion

Diagram 3

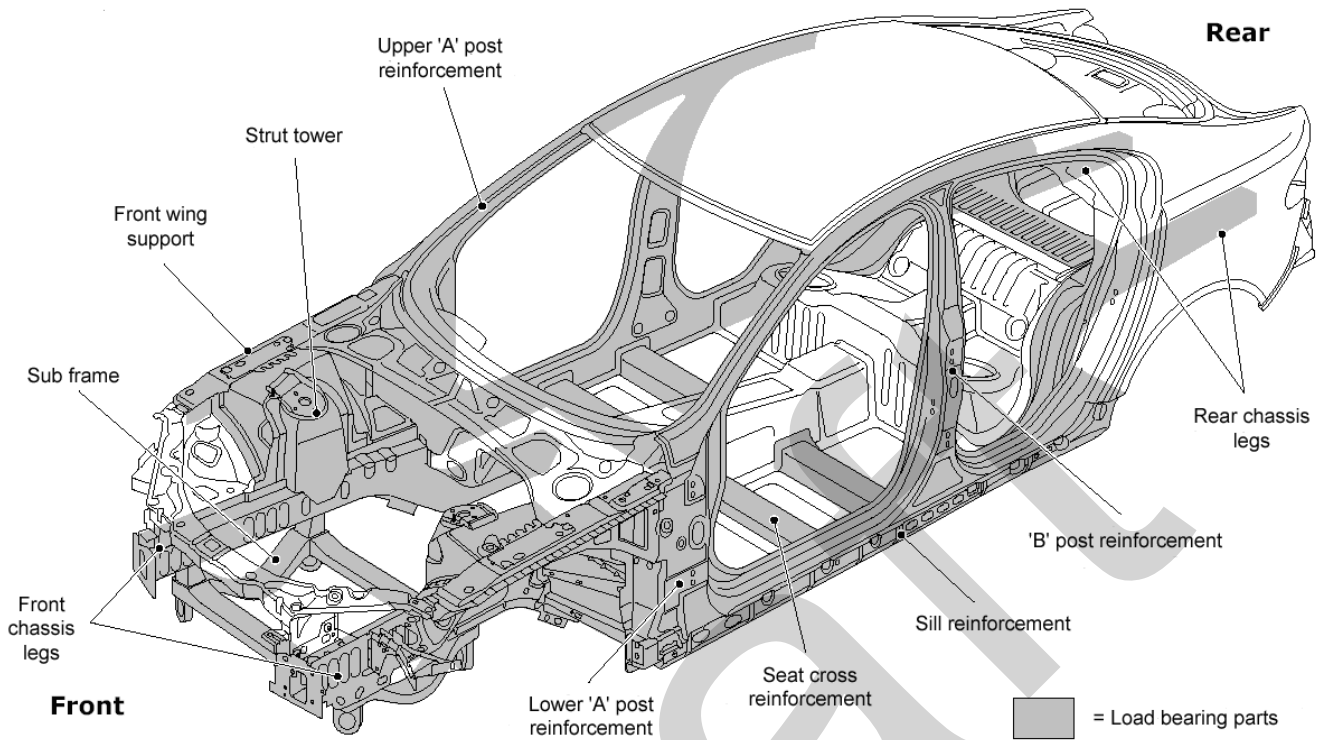
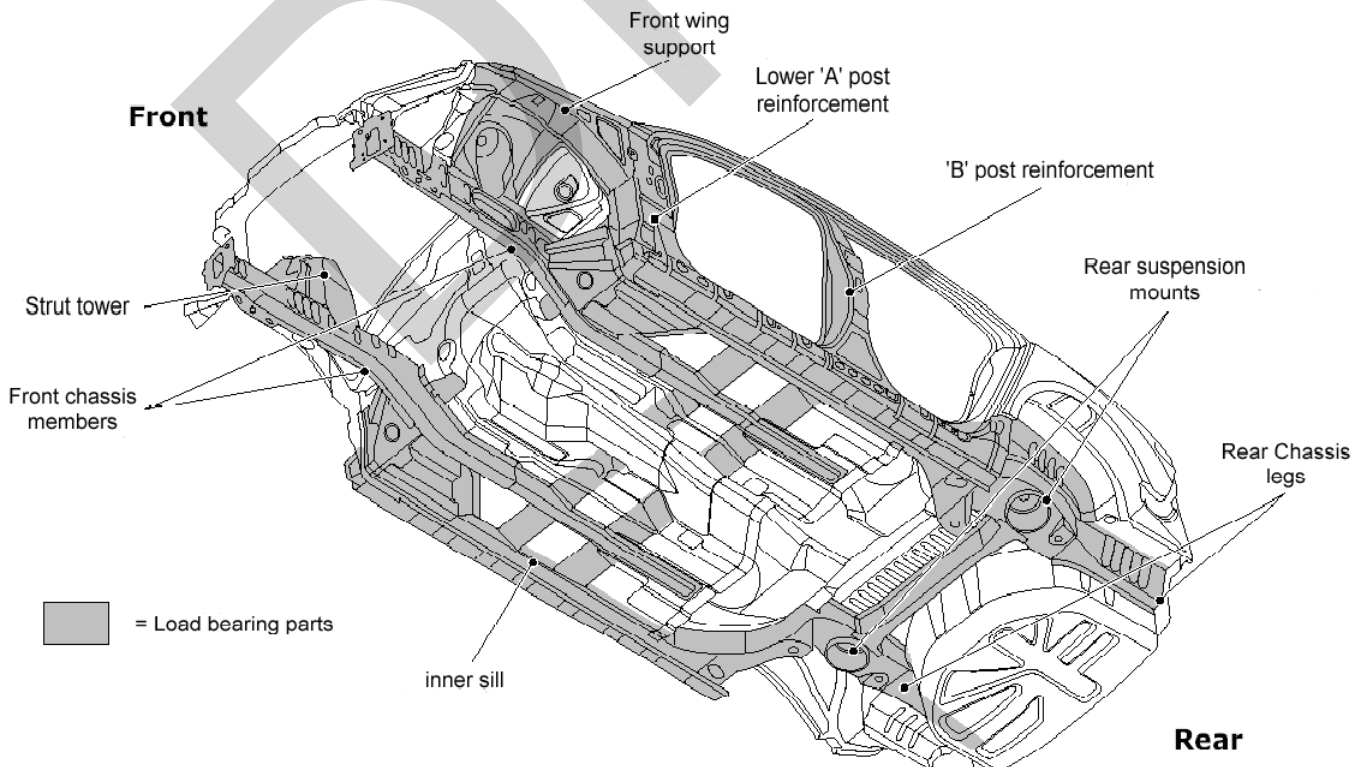

Diagram 4



## Appendix B – Tyre Load Index Tables

### Load Rating

The permitted maximum laden weight of an axle is that shown on the manufacturer's plate. The load capacity of tyres on older vehicles not fitted with a manufacturer's plate displaying axle weights must be assumed suitable, unless there is indisputable evidence to the contrary. If a Class 5 or 7 vehicle has a 'Ministry' plate showing lower axle weights not to be exceeded in Great Britain, these must be used instead of those shown on the manufacturer's plate.

The tyre load index tables displayed below show the load rating for both single wheel and twin wheel configurations, for example 121/120 = 2900 single, 5600 dual.

If a tyre has only one load index marked, then that index refers to use in single formation. Such tyres can be used in dual formation by applying the following formula: Maximum load shown x 1.91 = dual formation maximum load.

A tyre not marked with a load index must be assumed to meet the load capacity requirements.

### Load Index Tables

Load Index	Single Kg	Dual Kg		Load Index	Single Kg	Dual Kg		Load Index	Single Kg	Dual Kg
70	670	1340		110	2120	4240		150	6700	13400
71	690	1380		111	2180	4360		151	6900	13800
72	710	1420		112	2240	4480		152	7100	14200
73	730	1460		113	2300	4600		153	7300	14600
74	750	1500		114	2360	4720		154	7500	15000
75	774	1548		115	2430	4860		155	7750	15500
76	800	1600		116	2500	5000		156	8000	16000
77	824	1648		117	2570	5140		157	8250	16500
78	850	1700		118	2640	5280		158	8500	17000
79	874	1748		119	2720	5440		159	8750	17500
80	900	1800		120	2800	5600		160	9000	18000
81	924	1848		121	2900	5800		161	9250	18500
82	950	1900		122	3000	6000		162	9500	19000
83	974	1948		123	3100	6200		163	9750	19500
84	1000	2000		124	3200	6400		164	10000	20000
85	1030	2060		125	3300	6600		165	10300	20600
86	1060	2120		126	3400	6800		166	10600	21200
87	1090	2180		127	3500	7000		167	10900	21800
88	1120	2240		128	3600	7200		168	11200	22400
89	1160	2320		129	3700	7400		169	11600	23200
90	1200	2400		130	3800	7600		170	12000	24000
91	1230	2460		131	3900	7800		171	12300	24600
92	1260	2520		132	4000	8000		172	12600	25200
93	1300	2600		133	4120	8240		173	13000	26000
94	1340	2680		134	4240	8480		174	13400	26800
95	1380	2760		135	4360	8720		175	13800	27600
96	1420	2840		136	4480	8960		176	14200	28400
97	1460	2920		137	4600	9200		177	14600	29200
98	1500	3000		138	4720	9440		178	15000	30000
99	1550	3100		139	4860	9720		179	15500	31000
100	1600	3200		140	5000	10000				
101	1650	3300		141	5150	10300				
102	1700	3400		142	5300	10600				
103	1750	3500		143	5450	10900				
104	1800	3600		144	5600	11200				
105	1850	3700		145	5800	11600				
106	1900	3800		146	6000	12000				
107	1950	3900		147	6150	12300				
108	2000	4000		148	6300	12600				
109	2060	4120		149	6500	13000				

## Appendix C – Seat Belt Fitment Tables

### Seat Belt Fitment Tables

#### Three-Wheeled Vehicles First Used Before 17 June 1999

Date of First Use	Unladen Weight	Number of forward facing rear seats	Seat Belt Fitment
Before 1 January 1965	N/A	N/A	None
On or after 1 September 1970	255kg or less	N/A	None
	More than 255kg*	N/A	A, F and M
Before 1 April 1981	More than 410kg	N/A	A, F and M
Before 1 April 1987	More than 410kg	N/A	B, F and M
On or after 1 April 1987	More than 410kg	Two or less	B, G and N
		More than two	B, G and O

\*Except for amateur built vehicles less than 410kg unladen weight, equipped with a driving seat of a type requiring the driver to sit astride it which do not require seat belts.

#### Tricycles and Quadricycles First Used on or After 17 June 1999

Seat	Belt Requirements
<b>Driver's seat</b>	3 point lap and diagonal belt (may be static or inertia), harness belt or disabled persons belt.
<b>Outboard (front) passenger seat</b>	
<b>Centre front seat</b>	A lap belt, 3 point lap and diagonal belt (may be static or inertia), harness belt or disabled persons belt
<b>Forward facing rear seats *</b>	A lap belt, 3 point lap and diagonal belt (may be static or inertia), harness belt, disabled persons belt or child restraint.

\* Includes outboard forward facing seats fitted to un-bodied tricycles

**Notes** - Seat belts are not required on:

- three-wheeled mopeds
- quadricycles having an ULW of not more than 250kg
- tip up occasional seats
- a sit astride, saddle type driver's seat on unbodied tricycles or quadricycles
- any sit astride, saddle type passenger seat that is immediately in front or behind the driver in a longitudinal plane

Some unbodied vehicles may have been Type Approved without seat belts. These are acceptable, provided there is evidence that they have been Type Approved to 92/61/EEC or 2002/24/EC. This information will normally appear on the manufacturer's plate.

#### Passenger Vehicles, Motor Caravans and Ambulances up to Eight Passenger Seats

A 'passenger vehicle' is a vehicle constructed solely for the carriage of passengers and their effects.

A 'motor caravan' is a motor vehicle which is constructed or adapted for the carriage of passengers and their effects and with permanently installed equipment and facilities which are reasonably necessary to enable the vehicle to provide mobile living accommodation. Motor caravans are in Class 4 or 5 depending on their seating capacity and regardless of their size or weight.

## Appendix C – Seat Belt Fitment Tables

An 'ambulance' is a motor vehicle which is specially designed and constructed (and not merely adapted) for carrying as equipment permanently fixed to the vehicle, equipment used for medical, dental, or other health purposes and is used primarily for the carriage of persons suffering from illness, injury or disability.

### Driver's and Specified Front Passenger Seat

A	A belt which restrains the upper part of the body (but need not include a lap belt)
B	A 3 point belt or disabled person's belt
C	Any of the following: <ul style="list-style-type: none"> <li>• 3 point inertia reel belt</li> <li>• <b>retractable</b> lap belt</li> <li>• disabled person's belt</li> <li>• child restraint (not driver's seats)</li> </ul>
D	For the driver's seat, any of the following: <ul style="list-style-type: none"> <li>• 3 point belt</li> <li>• lap belt</li> <li>• disabled person's belt</li> </ul> <p>There is no requirement for the specified front passenger seat to have a belt.</p>
E	Any of the following: <ul style="list-style-type: none"> <li>• 3 point inertia reel belt</li> <li>• disabled person's belt</li> <li>• child restraint (not driver's seats)</li> </ul>

### Other Forward Facing Front Passenger Seats

F	None
G	Any of the following: <ul style="list-style-type: none"> <li>• 3 point belt</li> <li>• lap belt</li> <li>• disabled person's belt</li> </ul>
H	Any of the following: <ul style="list-style-type: none"> <li>• 3 point inertia reel belt</li> <li>• lap belt</li> <li>• disabled person's belt</li> </ul>
J	Any of the following: <ul style="list-style-type: none"> <li>• 3 point inertia reel belt</li> <li>• retractable lap belt</li> <li>• disabled person's belt</li> <li>• child restraint</li> </ul>
K	3 point belt or lap belt
L	Any of the following: <ul style="list-style-type: none"> <li>• 3 point inertia reel belt</li> <li>• disabled person's belt</li> <li>• child restraint</li> </ul>



## Appendix C – Seat Belt Fitment Tables

### Rear Seats

M	None
N	In forward facing rear seats: A point inertia reel belt in at least one seat, or any of the following in both seats: <ul style="list-style-type: none"> <li>• a three point belt</li> <li>• a lap belt</li> <li>• a disabled person's belt</li> </ul>
O	In forward facing rear seats any of the following: <ul style="list-style-type: none"> <li>• 3 point inertia reel belt on an outboard seat and a 3 point static or inertia reel belt, lap belt, disabled persons belt or child restraint for at least one other seat</li> <li>• static 3 point belt for one seat and a disabled person's belt or child restraint for at least one other seat</li> <li>• 3 point belt, lap belt, disabled person's belt or child restraint to each seat</li> </ul>
P	In forward and rearward facing rear seats any of the following: <ul style="list-style-type: none"> <li>• 3 point inertia reel belt</li> <li>• disabled persons belt</li> <li>• child restraint</li> </ul>
Q	Any of the following: <ul style="list-style-type: none"> <li>• 3 point inertia reel belt</li> <li>• <b>retractable</b> lap belt</li> <li>• disabled person's belt</li> <li>• child restraint</li> </ul>
R	Any of the following: <ul style="list-style-type: none"> <li>• 3 point inertia reel belt</li> <li>• <b>retractable</b> lap belt</li> <li>• disabled person's belt</li> <li>• child restraint</li> </ul> <p><b>Note:</b> Retractable lap belts may be fitted on any exposed seat where there are no seats or surfaces directly in front. They are acceptable on non exposed seats only if an appropriate energy absorbing seat or surface is present in front.</p>
S	In exposed forward facing seats (any rear seat which is not immediately behind a forward facing seat), a 3 point belt or lap belt.
T	In forward facing rear seats any of the following: <ul style="list-style-type: none"> <li>• 3 point inertia reel belt</li> <li>• disabled person's belt</li> <li>• child restraint</li> </ul>

## Appendix C – Seat Belt Fitment Tables

### Passenger Vehicles, Motor Caravans and Ambulances with up to Eight Passenger Seats

Table 1 - Vehicles with an unladen weight of 2540kg or less

Date of First Use	Forward facing rear seats	Seat Belt Fitment
Before 1 Jan 1965	N/A	None
Before 1 April 1981	N/A	A, F and M
Before 1 April 1987	N/A	B, F and M
On or after 1 April 1987	Two or less	B, G and N
	More than two	B, G and O

Table 2 - Vehicles with an unladen weight more than 2540kg

Date of First Use	Forward facing rear seats	Design Gross Weight	Seat Belt Fitment
Before 1 October 1988	N/A	N/A	None
Before 1 October 2001	Two or less	N/A	B, G and N
	More than two	3500kg or less	B, G and M
		More than 3500kg	None
On or after 1 October 2001	N/A	3500kg or less	B, L and T
		More than 3500kg	C, J and R

### Minibuses, Motor Caravans and Ambulances with 9 - 16 Passenger Seats

A **'minibus'** is a motor vehicle constructed or adapted to carry more than eight, but no more than sixteen seated passengers.

A **'motor caravan'** is a motor vehicle which is constructed or adapted for the carriage of passengers and their effects and with permanently installed equipment and facilities which are reasonably necessary to enable the vehicle to provide mobile living accommodation. Motor caravans are in Class 4 or 5 depending on their seating capacity and regardless of their size or weight.

An **'ambulance'** is a motor vehicle which is specially designed and constructed (and not merely adapted) for carrying as equipment permanently fixed to the vehicle, equipment used for medical, dental, or other health purposes and is used primarily for the carriage of persons suffering from illness, injury or disability.

Date of First Use	Weight	Passenger Seats	Seat Belt Fitment
Before 1 Jan 1965	N/A	N/A	None
Before 1 October 1982	ULW 2540kg or less	9 - 16	A, F and M
	ULW more than 2540kg	9 - 16	None
Before 1 October 1988	ULW 2540kg or less	9 - 16	B, F and M
	ULW more than 2540kg	9 - 16	None
Before 1 October 2001	DGW 3500kg or less	9 - 16	B, G and M
	DGW more than 3500kg	9 - 16	None
On or after 1 October 2001	DGW 3500kg or less	9 - 12	B, L and T
		13 - 16	C, L and T
	DGW more than 3500kg	9 - 16	C, J and R

## Appendix C – Seat Belt Fitment Tables

### Coaches

A **'coach'** is a motor vehicle which is constructed or adapted to carry more than 16 seated passengers, with a DGW of more than 7,500kg and a maximum speed in excess of 60mph.

Date of First Use	Seat Belt Fitment
Before 1 October 1988	None
Before 1 October 2001	D, G and S
On or after 1 October 2001	C, J and R

**Other Buses** (Except those designed for urban use with standing passengers)

A **'bus'** is a motor vehicle which is constructed or adapted to carry more than eight seated passengers (see also Minibus).

Date of First Use	Design Gross Weight	Seat Belt Fitment
Before 1 October 2001	N/A	None
On or after 1 October 2001	DGW 3500kg or less	E, L and T
	DGW more than 3500kg	C, J and R

### Goods Vehicles

A **'goods vehicle'** is a motor vehicle constructed or adapted for use for the carriage or haulage of goods or burden of any description.

Date of First Use	Unladen Weight	Seat Belt Fitment
Before 1 April 1967	N/A	None
Before 1 April 1980	More than 1525kg	None
	1525kg or less	A, F and M
Before 1 April 1981*	N/A	A, F and M
Before 1 April 1987*	N/A	B, F and M
On or after 1 April 1987	N/A	B, G and M

\* Except a model of vehicle manufactured before 1 October 1979 and first used before 1st April 1982.